

# ACCU SPOT 575™



## User Instructions

American DJ®  
American DJ World Headquarters:  
6122 S. Eastern Ave. Los Angeles, CA 90040 USA  
Tel: 323-582-2650 / Fax: 323-725-6100  
Web: [www.americandj.com](http://www.americandj.com) / E-mail: [info@americandj.com](mailto:info@americandj.com)

American DJ Europe  
Junostraat 2  
6468 EW Kerkrade  
Netherlands  
[service@americandjeurope.com](mailto:service@americandjeurope.com) / [www.americandjeurope.com](http://www.americandjeurope.com)  
Tel: +31 45 546 85 00 / Fax: +31 45 546 85 99

Rev. 4/08

American DJ®  
6122 S. Eastern Ave.  
Los Angeles CA. 90040  
[www.americandj.com](http://www.americandj.com)



# Accu Spot 575

## Table of Contents

- Unpacking.....3
- Introduction.....3
- Customer Support.....3
- Safety Precautions.....4
- Handling Precautions.....5
- Discharge Lamp Warnings.....5
- Registration.....6
- Features.....6
- Mounting.....7
- Controls and Functions.....8
- Set-Up.....11
- System Menu.....14
- Editing Program.....32
- Error Codes.....37
- Operating Modes.....39
- Lamp and Fuse Replacement.....41
- DMX Traits.....43
- Gobo Replacement.....48
- Cleaning.....49
- Trouble Shooting.....49
- Warranty.....50
- Specifications.....51

### Accu Spot 575

### Specifications

<b>Model:</b>	<b>Accu Spot 575</b>
<b>Voltage*:</b>	<input type="checkbox"/> 100VAC, 50Hz; <input type="checkbox"/> 120VAC, 50Hz; <input type="checkbox"/> 208VAC, 50Hz; <input type="checkbox"/> 220VAC, 50Hz; <input type="checkbox"/> 230VAC, 50Hz; <input type="checkbox"/> 240VAC, 50Hz; or <input type="checkbox"/> 100VAC, 60Hz; <input type="checkbox"/> 120VAC, 60Hz; <input type="checkbox"/> 208VAC, 60Hz; <input type="checkbox"/> 220VAC, 60Hz; <input type="checkbox"/> 230VAC, 60Hz; <input type="checkbox"/> 240VAC, 60Hz;
<b>Lamp:</b>	ZB-MSR575/2, 575w
<b>Dimensions:</b>	18.9”(L) x 18.1”(W) x 24.8”(H) 480mm x 460mm x 630mm
<b>Colors:</b>	8 Plus White
<b>Gobos:</b>	Wheel 1: 6 Rotating + Spot Wheel 2: 7 Static + Spot 27mm Outside/ 22mm Viewable
<b>Weight:</b>	81 Lbs. / 37 kgs.
<b>Fuse:</b>	12A (120v) / 6A/6.3A (220v)
<b>Duty Cycle:</b>	None
<b>DMX:</b>	16 Channels
<b>Sound Active:</b>	Yes
<b>Working Position:</b>	Any Safe, Secure Position
<b>Warranty:</b>	1 Year (365 days)

\*Voltage is preset at the factory and is not user selectable

**Please Note:** Specifications and improvements in the design of this unit and this manual are subject to change without any prior written notice.

## 1-YEAR LIMITED WARRANTY

A. American DJ® hereby warrants, to the original purchaser, American DJ® products to be free of manufacturing defects in material and workmanship for a period of 1 Year (365 days) from the date of purchase. This warranty shall be valid only if the product is purchased within the United States of America, including possessions and territories. It is the owner's responsibility to establish the date and place of purchase by acceptable evidence, at the time service is sought.

B. For warranty service, send the product only to the American DJ® factory. All shipping charges must be pre-paid. If the requested repairs or service (including parts replacement) are within the terms of this warranty, American DJ® will pay return shipping charges only to a designated point within the United States. If the entire instrument is sent, it must be shipped in its original package. No accessories should be shipped with the product. If any accessories are shipped with the product, American DJ® shall have no liability whatsoever for loss of or damage to any such accessories, nor for the safe return thereof.

C. This warranty is void if the serial number has been altered or removed; if the product is modified in any manner which American DJ® concludes, after inspection, affects the reliability of the product; if the product has been repaired or serviced by anyone other than the American DJ® factory unless prior written authorization was issued to purchaser by American DJ®; if the product is damaged because not properly maintained as set forth in the instruction manual.

D. This is not a service contract, and this warranty does not include maintenance, cleaning or periodic check-up. During the period specified above, American DJ® will replace defective parts at its expense, and will absorb all expenses for warranty service and repair labor by reason of defects in material or workmanship. The sole responsibility of American DJ® under this warranty shall be limited to the repair of the product, or replacement thereof, including parts, at the sole discretion of American DJ®. All products covered by this warranty were manufactured after January 1, 1990, and bear identifying marks to that effect.

E. American DJ® reserves the right to make changes in design and/or improvements upon its products without any obligation to include these changes in any products theretofore manufactured.

F. No warranty, whether expressed or implied, is given or made with respect to any accessory supplied with products described above. Except to the extent prohibited by applicable law, all implied warranties made by American DJ® in connection with this product, including warranties of merchantability or fitness, are limited in duration to the warranty period set forth above. And no warranties, whether expressed or implied, including warranties of merchantability or fitness, shall apply to this product after said period has expired. The consumer's and or Dealer's sole remedy shall be such repair or replacement as is expressly provided above; and under no circumstances shall American DJ® be liable for any loss or damage, direct or consequential, arising out of the use of, or inability to use, this product.

G. This warranty is the only written warranty applicable to American DJ® Products and supersedes all prior warranties and written descriptions of warranty terms and conditions heretofore published.

H. Lamps are not covered under this or any other warranty, either written or implied.

**Unpacking:** Thank you for purchasing the Accu Spot 575 by American DJ®. Every Accu Spot 575 has been thoroughly tested and has been shipped in perfect operating condition. Carefully check the shipping carton for damage that may have occurred during shipping. If the carton appears to be damaged, carefully inspect your fixture for any damage and be sure all equipment necessary to operate the unit has arrived intact. In the event damage has been found or parts are missing, please contact our toll free customer support number for further instructions. Please do not return this unit to your dealer without contacting customer support first.

**Introduction:** The Accu Spot 575 is a sixteen channel, moving head, intelligent DMX fixture. The fixture can operate in three different operating modes; stand alone, sound-active, or in a Master/Slave configuration. The Accu Spot 575 comes with several built in programs that can be used, while operating as a stand alone unit or when used in multiples linked in a master/slave configuration. *For best results use fog or special effects smoke to enhance the beams projections.*

**During the initial start-up or use of this product a light smoke or smell may arise from the unit. This is a normal process and is cause by the heat associated with the lamp.**

**Customer Support:** American DJ® provides a toll free customer support line, to provide help and to answer any question should you encounter problems during your set up or initial operation. You may also visit us on the web at [www.americandj.com](http://www.americandj.com) for any comments or suggestions. Service Hours are Monday through Friday 9:00 a.m. to 5:00 p.m. Pacific Standard Time.

Voice: (800) 322-6337

Fax: (323) 582-2941

E-mail: [support@americandj.com](mailto:support@americandj.com)

To purchase parts online visit <http://parts.americandj.com>

**Warning!** To prevent or reduce the risk of electrical shock or fire, do not expose this unit to rain or moisture.

**Warning!** *This may cause severe eye damage. Avoid looking directly into the light source at all times!*

***For Your Own Personal Safety, Please Read and Understand This Manual Completely Before You Attempt To Install Or Operate This Unit!***

- To reduce the risk of electrical shock or fire, do not expose this unit rain or moisture
- Do not spill water or other liquids into or on to your unit.
- Be sure that the local power outlet match that of the required voltage for your unit.
- Do not attempt to operate this unit if the power cord has been frayed or broken.
- Do not attempt to remove or break off the ground prong from the electrical cord. This prong is used to reduce the risk of electrical shock and fire in case of an internal short.
- Disconnect from main power before making any type of connection.
- Do not remove the cover under any conditions. There are no user serviceable parts inside.
- Never operate this unit when it's cover is removed.
- Always be sure to mount this unit in an area that will allow proper ventilation. Allow about 6" (15cm) between this device and a wall.
- Do not attempt to operate this unit, if it becomes damaged.
- This unit is intended for indoor use only, use of this product outdoors voids all warranties.
- Always mount this unit in safe and stable matter.
- Power-supply cords should be routed so that they are not likely to be walked on or pinched by items placed upon or against them, paying particular attention to cords at plugs, convenience receptacles, and the point where they exit from the appliance.
- Cleaning -The fixture should be cleaned only as recommended by the manufacturer. See page 41 for cleaning details.
- Heat -This fixture should be situated away from heat sources such as radiators, heat registers, stoves, or other appliances (including amplifiers) that produce heat.
- The fixture should be serviced by qualified service personnel when:
  - A. Objects have fallen, or liquid has been spilled into the appliance.
  - B. The appliance has been exposed to rain or water.
  - C. The appliance does not appear to operate normally or exhibits a marked change in performance.

**Fixture Cleaning:** Due to fog residue, smoke, and dust cleaning the internal and external optical lenses and mirror should be carried out periodically to optimize light output. Cleaning frequency depends on the environment in which the fixture operates (I.e. smoke, fog residue, dust, dew). In heavy club use we recommend cleaning on a monthly basis. Periodic cleaning will ensure longevity, and crisp output.

1. Use normal glass cleaner and a soft cloth to wipe down the outside casing.
2. Use a brush to wipe down the cooling vents and fan grill.
3. Clean the external optics and mirror with glass cleaner and a soft cloth every 20 days.
4. Clean the internal optics with glass cleaner and a soft cloth every 30-60 days.
5. Always be sure to dry all parts completely before plugging the unit back in.

**Trouble Shooting:** Listed below are a few common problems that you may encounter, with solutions.

***No light output from the unit;***

1. Be sure you have connected your unit into a standard 120v wall outlet.
2. Be sure the external fuse has not blown. The fuse is located at the rear of the unit.
3. Remove the lamp holder and be sure the lamp is seated in its socket properly. Occasionally lamps become loose during shipping be sure the lamp is push in to its socket all the way.
4. Be sure the fuse holder is completely and properly seated.

***Unit does not respond to sound;***

1. Low frequencies (bass) should cause the unit to react to sound. Tapping on the microphone, quiet or high pitched sounds may not activate the unit.

## Accu Spot 575

## Gobo Replacement

This unit comes with interchangeable gobos for both gobo wheels. Changing the gobos is a easy procedure. Follow the instructions below.

**Caution!** *Never open the unit when in use. Always disconnect the main power before attempting to change the gobos.*

1. Remove the corresponding half of the head where the gobo wheel is located. **The wheel with static gobos is located on the top half of the moving head, and the wheel with the rotating gobos is located on the bottom half of the moving head.**
2. Each half of the head has four spring loaded phillips screws that secure it. Unscrew the four phillips screws and remove the half of the head shell.
3. When you remove the shell you will be able to access the gobo wheel. Turn the wheel with your hand until you come across the gobo you would like to change.
4. With your finger push the gobo out towards the front and then slide the gobo up and out of the wheel. When doing this you do not need a lot of pressure.
5. Change the gobo by sliding the new gobo into place and reassemble the shell.

**Note:** *If you want to add your own custom gobo, you will have to remove the retainer ring that secures the gobo to the gobo frame. Remove the retainer ring using your finger nail or flat head screwdriver. Secure your gobo to the gobo frame using the retainer ring and slide the new gobo into place in the wheel.*

## Accu Spot 575

## Handling Precautions

**Caution!** There are no user serviceable parts inside this unit. Do not attempt any repairs yourself, doing so will void your manufactures warranty. In the unlikely event your unit may require service please contact American DJ®.

*During operation the housing may become extremely hot. Avoid touching the unit with bare hands while in use.*

*American DJ® will not accept any liability for any resulting damages caused by the non-observance of this manual or any unauthorized modification to this unit.*

## Accu Spot 575

## Discharge Lamp Warning

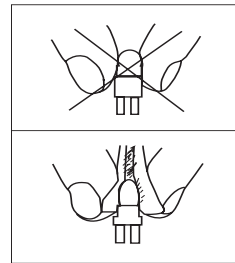

This fixture is fitted with a discharge lamp which is highly susceptible to damage if improperly handled. Never touch the lamp with your bare fingers as the oil from your hands will shorten lamp life. Also, never move the fixture until the lamps have had ample time to cool. Remember, lamps are not covered under warranty conditions.

This unit emits intense UV radiation which is harmful to the eyes and skin. The intense luminance of the lamp can cause severe damage to the retina. Never operate this unit without it's covers, these covers have been specially designed to shield against UV radiation.

**Epileptic Warning:** *Those suffering from epilepsy should avoid looking directly into the lamp at all times.*

Avoid switching the fixture on and off repeatedly in short intervals as this will reduce lamp life and intensity.

To achieve the intensity associated with discharge lamps, these lamps use gas sealed in a high pressure environment to emit a brilliant output. Due to the high pressure involved with the construction of the lamp, the lamp may explode during prolonged extensive use. This risk is increased with age, added care is encouraged when dealing with older lamps. Extreme caution should be used when operating this or any fixture fitted with a gas discharge lamp. Never open this unit while in use.

**Accu Spot 575****General Instructions**

To optimize the performance of this product, please read these operating instructions carefully to familiarize yourself with the basic operations of this unit. These instructions contain important safety information regarding the use and maintenance of this unit. Please keep this manual with the unit, for future reference.

**Accu Spot 575****Product Registration**

The Accu Spot 575 carries a one year limited warranty. Please fill out the enclosed warranty card to validate your purchase. All returned service items whether under warranty or not, must be freight pre-paid and accompany a return authorization (R.A.) number. The R.A. number must be clearly written on the outside of the return package. A brief description of the problem as well as the R.A. number must also be written down on a piece of paper and included in the shipping carton. If the unit is under warranty, you must provide a copy of your proof of purchase invoice. You may obtain a R.A. number by contacting our customer support team on our toll free customer support number. All packages returned to the service department not displaying a R.A. number on the outside of the package will be returned to the shipper at the shippers cost.

**Accu Spot 575****Features**

- Micro-Stepping Motors for Smooth Color and Gobo Transitions
- DMX-512 Protocol Compatible (Uses Sixteen DMX Channels)
- Independent Gobo and Color Wheels
- 6 Rotating Gobos, 1 Dichroic + Spot - All Replaceable
- 8 Colors, Plus White - With Rainbow
- 3 Operating Modes - Master/Slave; Stand Alone; Sound Active
- Internal Microphone
- ZB-MSD575/2 Discharge Lamp, 575w
- Edit and Save Scenes into the Memory
- Manual Focus Lens
- Variable Strobe (1-12 fps)
- Switchable 540° to 630° Pan Movement
- 265° Tilt Movement
- Digital Display for Address and Function Setting

**Accu Spot 575****DMX Traits cont.**

Channel	Value	Function
16 ↓		LAMP ON/OFF, RESET, INTERNAL PROGRAMS
	60 - 79	LAMP OFF
	80 - 84	ALL MOTOR RESET
	85 - 87	SCAN MOTOR RESET
	88 - 90	COLOR WHEEL MOTOR RESET
	91 - 93	GOBO WHEEL MOTOR RESET
	94 - 96	SHUTTER/DIMMER MOTOR RESET
	97 - 99	OTHER MOTOR RESET
	100 - 119	INTERNAL PROGRAM 1
	120 - 139	INTERNAL PROGRAM 2
	140 - 159	INTERNAL PROGRAM 3
	160 - 179	INTERNAL PROGRAM 4
	180 - 199	INTERNAL PROGRAM 5
	200 - 219	INTERNAL PROGRAM 6
	220 - 239	INTERNAL PROGRAM 7
	240 - 255	SOUND ACTIVE

Accu Spot 575		DMX Traits cont.
Channel	Value	Function
12 ↓	0 - 31	<u>SHUTTER &amp; STROBE</u> SHUTTER CLOSED
	32 - 63	SHUTTER OPEN
	64 - 95	STROBE EFFECT
		SLOW → FAST
	96 - 127	SHUTTER OPEN
	128 - 159	PULSE EFFECT
	160 - 191	SHUTTER OPEN
↓	192 - 223	RANDOM STROBE EFFECT
		SLOW → FAST
	224 - 255	SHUTTER OPEN
13	0 - 255	<u>DIMMER (INTENSITY)</u> INTENSITY 0% - 100%
14 ↓	0 - 191	<u>IRIS</u> DIAMETER ADJUSTMENT MAXIMUM → MINIMUM
	192 - 223	PULSE CLOSING
		FAST → SLOW
	224 - 255	PULSE OPENING SLOW → FAST
15 ↓	0 - 225	SPEED OF PAN/TILT MOVEMENT
	226 - 235	SPEED MAX - MIN
	236 - 245	BLACKOUT BY MOVEMENT
	246 - 255	BLACKOUT BY ALL WHEEL CHANGE
		NO FUNCTION
16 ↓	0 - 19	<u>LAMP ON/OFF, RESET, INTERNAL PROGRAMS</u>
	20 - 39	COLOR CHANGE NORMAL
	40 - 59	COLOR CHANGE TO ANY POSITION
		LAMP ON

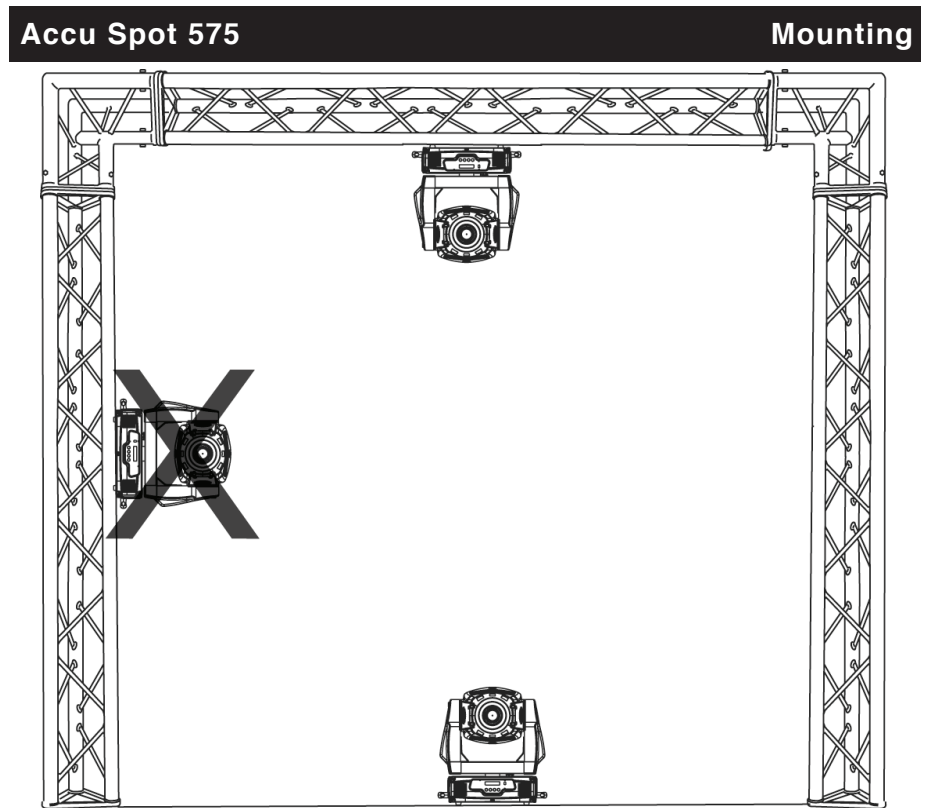

The Accu Spot 575 is fully operational in two different mounting positions, hanging upside-down from a ceiling or set on a flat level surface. To avoid internal damage to the unit, never mount the unit on its side as illustrated above. Be sure this fixture is kept at least 0.5m away from any flammable materials (decoration etc.). Always use and install the supplied safety cable as a safety measure to prevent accidental damage and/or injury in the event the clamp fails. Never use the carrying handles for secondary attachment.

FRONT

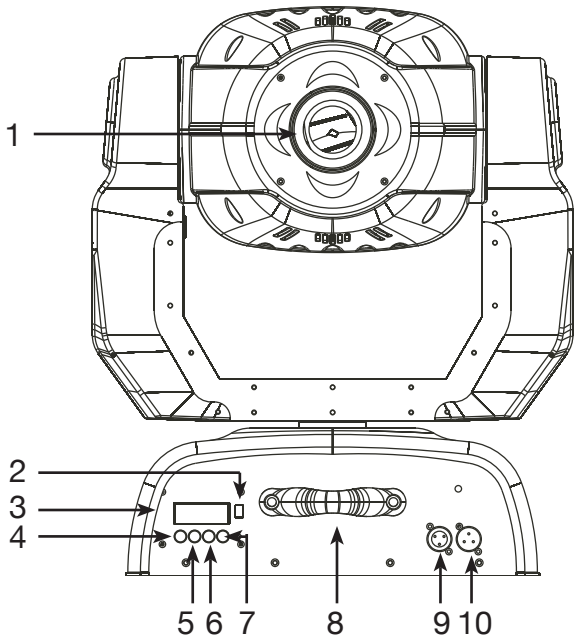

REAR

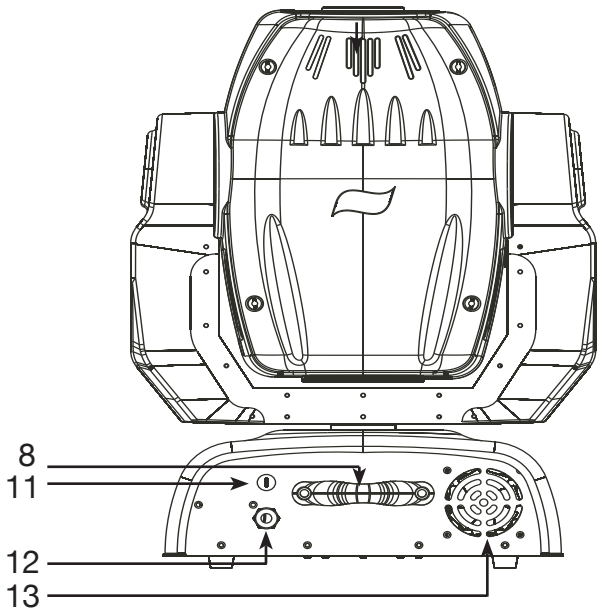

Channel	Value	Function
9	0 - 31	<u>ROTATING PRISM, PRISM/GOBO MACROS</u> OPEN
	32 - 63	ROTATING PRISM 1
	64 - 95	ROTATING PRISM 2
	96 - 127	ROTATING PRISM 3
	128 - 135	MACRO 1
	136 - 143	MACRO 2
	144 - 151	MACRO 3
	152 - 159	MACRO 4
	160 - 167	MACRO 5
	168 - 175	MACRO 6
	176 - 183	MACRO 7
	184 - 191	MACRO 8
	192 - 199	MACRO 9
	200 - 207	MACRO 10
	208 - 215	MACRO 11
	216 - 223	MACRO 12
224 - 231	MACRO 13	
232 - 239	MACRO 14	
240 - 247	MACRO 15	
248 - 255	MACRO 16	
10	0 - 127	<u>ROTATING PRISM INDEX, ROTATING PRISM</u> PRISM INDEXING
	128 - 187	FORWARDS PRISM ROTATION FAST → SLOW
	188 - 193	NO ROTATION
	194 - 255	BACKWARDS PRISM ROTATION SLOW → FAST
11	0 - 255	<u>FOCUS</u> ADJUSTMENT FROM FAR - NEAR



Accu Spot 575		DMX Traits cont.
Channel	Value	Function
6 ↓	170 - 189	<u>ROTATING GOBOS CONT.</u> GOBO 6 SHAKE ROTATING GOBO WHEEL SCROLL SLOW → FAST
	190 - 255	
7 ↓	0 - 127	<u>ROTATING GOBO INDEX</u> GOBO INDEXING FORWARDS GOBO ROTATION FAST → SLOW NO ROTATION BACKWARDS GOBO ROTATION SLOW → FAST
	128 - 187	
	188 - 193	
	194 - 255	
8	0 - 13	<u>FIXED GOBOS</u> SPOT
	14 - 27	GOBO 1
	28 - 41	GOBO 2
	42 - 55	GOBO 3
	56 - 69	GOBO 4
	70 - 83	GOBO 5
	84 - 97	GOBO 6
	98 - 111	GOBO 7
	112 - 127	GOBO 1 SHAKE
	128 - 143	GOBO 2 SHAKE
	144 - 159	GOBO 3 SHAKE
	160 - 175	GOBO 4 SHAKE
	176 - 191	GOBO 5 SHAKE
	192 - 207	GOBO 6 SHAKE
	208 - 223	GOBO 7 SHAKE
224 - 255	GOBO WHEEL ROTATION SLOW → FAST	

## Accu Spot 575 Controls and Functions

- 1. Lens Assembly** - This is a high quality lens that is focused by using the Lamp Optimization in DMX Mode.
- 2. Software Update Input Jack** - This jack is used to update the latest software version into the unit.
- 3. Digital Display** - This display shows the menu and operating functions that you can choose from.
- 4. Mode/ESC Button** - This button is used to exit menus and to scroll backwards through certain menus only.
- 5. Up Button** - This button is used to scroll forward when navigating through the system menu.
- 6. Down Button** - This button is used to scroll backwards when navigating through the system menu.
- 7. Enter Button** - This button is used to select and confirm a function when working in the system menu. It is also used to exit certain menus.
- 8. Carrying Handles** - The includes built-in carrying handles. Be sure to always handle the unit by the built-in handles. Never lift or carrying the unit by head or yoke. Pulling on or transporting the unit by the moving head may severely damage the unit and will void the unit warranty.
- 7. Microphone** - This microphone receives external low frequencies to trigger the unit in Sound-Active mode. This microphone is designed to receive low frequency sounds only, tapping on the microphone and high pitch sounds may not trigger the unit.
- 9. XLR Output Jack** - This jack is used to transmit the incoming DMX signal to another DMX fixture, or transmit a Master/Slave signal to the next Accu Spot 575 in the chain. For best results in DMX or Master/Slave mode terminate this jack if it is the last unit in the chain. See "Terminator" on page 11.
- 10. XLR DMX Input Jack** - This jack is used to receive an incoming DMX signal or Master/Slave signal.
- 11. Fuse Holder** - This housing stores a 8 amp (4 amp 220v) GMA protective fuse. Never defeat the fuse, the fuse is designed to protect the

**Accu Spot 575****Controls and Functions**

electronics in the event of severe power fluctuations. Always be sure to replace the fuse with an exact match as the one being replaced, unless otherwise told to do so by an authorized American DJ® service technician.

**12. Power Cord Inlet** - This unit is equipped with a removable I.E.C. power cord. Be sure to only use the power cord included with the unit, this cord is designed to match the electrical requirements of the unit. Other cords may cause the unit to overheat or malfunction. Voltage may vary from venue to venue, when connecting this unit to a power supply be sure to connect to a matching power outlet. Never use this fixture if the ground prong has been removed or broken off. The ground prong is designed to reduce the risk of fire or electrical shock in the event the unit suffers from an internal short.

**13. Cooling Fan** - This unit is equipped with three high velocity variable fans to aid in the cooling process. These fans are designed to vary their velocity at different operating temperatures, to provide better cooling when the unit reached higher operating temperatures associated with long usage. Be sure to never obstruct the cooling fans during normal usage. Also, be sure to keep the vents clean at all times. A blocked or malfunctioning cooling system may shorten lamp life and unit reliability.

**Accu Spot 575****DMX Traits**

Channel	Value	Function
1	0 - 255	PAN MOVEMENT 8bit
2	0 - 255	PAN FINE 16bit
3	0 - 255	TILT MOVEMENT 8bit
4	0 - 255	TILT FINE 16bit
5	0 - 13 14 - 27 28 - 41 42 - 55 56 - 69 70 - 83 84 - 97 98 - 111 112 - 127 128 - 187  188 - 193 194 - 255	<u>COLOR WHEEL</u> OPEN/WHITE RED LIGHT BLUE GREEN YELLOW MAGENTA ORANGE PURPLE PINK FORWARDS RAINBOW EFFECT FAST → SLOW NO ROTATION BACKWARDS RAINBOW EFFECT SLOW → FAST
6	0 - 9 10 - 19 20 - 29 30 - 39 40 - 49 50 - 59 60 - 69 70 - 89 90 - 109 110 - 129 130 - 149 150 - 169	<u>ROTATING GOBOS</u> SPOT ROTATING GOBO 1 ROTATING GOBO 2 ROTATING GOBO 3 ROTATING GOBO 4 ROTATING GOBO 5 ROTATING GOBO 6 GOBO 1 SHAKE GOBO 2 SHAKE GOBO 3 SHAKE GOBO 4 SHAKE GOBO 5 SHAKE

**Optimizing Lamp Alignment:** This procedure centers the lamp in the reflector. Proper optimization will increase lamp life and ensure a bright crisp output. Improper optimization may add a yellow tint to the lamp output and reduce intensity. **NOTE: The lamp adjustment screws are labeled 1, 2, and 3.**

1. Be sure main power is disconnected and allow the unit to cool. If the you have just installed a new unit you can obviously skip this step.
2. Make a preliminary adjustment: Turn the three lamp adjustment thumb screws completely in (clockwise). Then back them each out (counter-clockwise) about three complete turns.
3. Turn the unit on and allow it to reset.
4. Using either a DMX controller or the control panel on the unit, strike the lamp and focus the light on a flat surface.
6. Center the hot-spot (the brightest part of the beam) using the 3 adjustment screws. Turn one screw at a time to drag the hot-spot diagonally across the projected image. If you cannot detect a hot-spot, adjust the lamp until the light is even.
7. To reduce a hot-spot, pull the lamp in by turning all three screws clockwise 1/4-turn at a time until the light is evenly distributed.
8. If the light is brighter around the edge than it is in the center, or if light output is low, the lamp is too far back in the reflector. "Push" the lamp out by turning the screws.

**Fuse Replacement:** The fuse holder located at the rear of the unit above the power cord. Disconnect from the main power supply. Insert a standard flat head screw driver in to the fuse holder housing, located on the back of the unit. Turn the screwdriver in counter-clockwise direction to remove the fuse holder. Remove the old fuse and discard it, replace the fuse with the same type. Insert the fuse back into it's housing.

**Power Supply:** Before plugging your unit in, be sure the source voltage in your area matches the required voltage for your American DJ® Accu Spot 575.™ The American DJ® Accu Spot 575 is available in a 120v and 230v version. Because line voltage may vary from venue to venue, you should be sure your unit voltage matches the wall outlet voltage before attempting to operate you fixture. Also be sure to only use the included I.E.C. power cable supplied with the unit, this cable matches the voltage and current requirements of the unit.

**DMX-512:** DMX is short for Digital Multiplex. This is a universal protocol used by most lighting and controller manufactures as a form of communication between intelligent fixtures and controllers. A DMX controller sends DMX data instructions from the controller to the fixture. DMX data is sent as serial data that travels from fixture to fixture via the DATA "IN" and DATA "OUT" XLR terminals located on all DMX fixtures (most controllers only have a DATA "OUT" terminal).

**DMX Linking:** DMX is a language allowing all makes and models of different manufactures to be linked together and operate from a single controller, as long as all fixtures and the controller are DMX compliant. *To ensure proper DMX data transmission, when using several DMX fixtures try to use the shortest cable path possible. The order in which fixtures are connected in a DMX line does not influence the DMX addressing. For example; a fixture assigned a DMX address of 1 may be placed anywhere in a DMX line, at the beginning, at the end, or anywhere in the middle. Therefore, the first fixture controlled by the controller could be the last fixture in the chain. When a fixture is assigned a DMX address of 1, the DMX controller knows to send DATA assigned to address 1 to that unit, no matter where it is located in the DMX chain.*

**Data Cable (DMX Cable) Requirements (For DMX and Master/Slave Operation):** The Accu Spot 575 can be controlled via DMX-512 protocol. The Accu Spot 575 is a sixteen channel DMX unit. The DMX address is set electronically using the controls on the front panel of the unit. Your fixture and your DMX controller require an approved DMX-512 110 Ohm Data cable for data input and data output (Figure 1). We recommend Accu-Cable DMX cables. If you are making



Figure 1

your own cables, be sure to use standard 110-120 Ohm shielded cable (This cable may be purchased at almost all pro lighting stores). Your cables should be made with a male and female XLR connector on either end of the cable. Also remember that DMX cable must be daisy chained and cannot be split.

**Notice:** Be sure to follow figures two and three when making your own cables. Do not use the ground lug on the XLR connector. Do not connect the cable's shield conductor to the ground lug or allow the shield conductor to come in contact with the XLR's outer casing. Grounding the shield could cause a short circuit and erratic behavior.

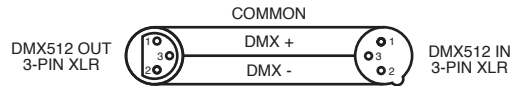

Figure 2

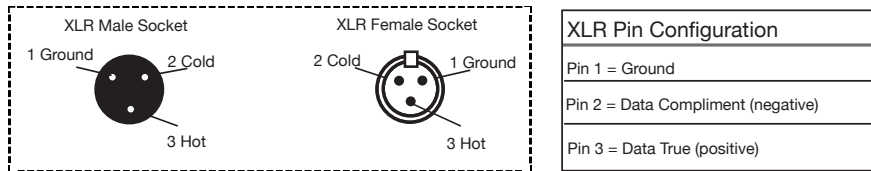

Figure 3

**Special Note: Line Termination.** When longer runs of cable are used, you may need to use a terminator on the last unit to avoid erratic behavior. A terminator is a 110-120 ohm 1/4 watt resistor which is connected between pins 2 and 3 of a male XLR connector (DATA + and DATA -). This unit is inserted in the female XLR connector of the last unit in your daisy chain to terminate the line. Using a cable terminator (ADJ part number Z-DMX/T) will decrease the possibilities of erratic behavior.



Termination reduces signal errors and avoids signal transmission problems and interference. It is always advisable to connect a DMX terminal. (Resistance 120 Ohm 1/4 W) between PIN 2 (DMX-) and PIN 3 (DMX+) of the last fixture.

Figure 4

**Caution:** Always replace with the exact same type lamp and fuse, unless otherwise specified by an authorized American DJ® service technician. Replacing with anything other than the specified part can damage your unit and will void your manufactures warranty.

**Warning:** If you continue to blow lamps or fuses, STOP using the unit. Contact customer support for further instructions, you may have to return the unit for servicing. Continuing to use the unit may cause serious damage.

**Lamp Replacement:** Caution! Never attempt to change the lamp while the fixture is plugged in. Always disconnect the main power and allow the unit ample time to cool before attempting to replace the lamp. Lamp replacement has been made simple by incorporating the a slide out lamp assembly that is retained by two phillips screws.

1. Be sure to follow the proper handling procedures that deal with discharge lamps.
2. Remove the three small screws labeled A,B, and C on the rear of the unit
3. After removing the screws, gently slide out the socket assembly from the rear of the unit to expose the lamp.
4. Carefully remove the old lamp and discard it in the trash.
5. Replace the lamp with an exact match and reassemble in reverse order.
6. After replacing the lamp follow the optimization procedures on the next page to be sure the lamp is center in the reflector

**Stand-Alone (Sound Active or Auto Program):** This mode allows a single unit to run to the beat of the music or run through a built-in program.

1. Access the main menu.
2. Tap the UP button until "PLAY" is displayed, and Press ENTER.
3. Tap the UP button until "AUTO" is displayed, and Press ENTER.
4. Press UP, to select "OFF", "RUN", or "AUDI". "RUN" will make the unit run through a built-in program. "AUDI" will make the unit sound active.
5. Select a mode, and press ENTER to confirm.
6. Press MODE/ESC if you want to return to the main menu.
7. You may change the show or invert the pan and tilt functions in the system menu by following the directions on pages 17-29.

**Master-Slave Operation (Sound Active or Auto Program):**

This function will allow you to link up to 16 units together and operate without a controller. The units can run a built-in program or run in sound active mode. In Master-Slave operation one unit will act as the controlling unit and the others will react to the controlling units programs. Any unit can act as a Master or as a Slave.

1. Daisy chain your units via the XLR connector on the rear of the unit. Use approved DMX-512 data cables to link your units together. Remember the Male XLR connector is the input and the Female XLR connector is the output. The first unit in the chain (master) will use the female XLR connector only - The last unit in the chain will use the male XLR connector only. For longer cable runs we suggest a terminator at the last fixture.
2. Tap the UP button until "PLAY" is displayed, and Press ENTER.
3. Tap the UP button to choose between "RUN" or "AUDI". "RUN" will make the units run through a built-in program. "AUDI" will make the units sound active.
4. Press UP, to select "ALON" or "MAST". Which means stand alone, or master/slave mode.
5. Select a mode, and press ENTER to confirm.
6. Press MODE/ESC if you want to return to the main menu
7. You may change the show or invert the pan and tilt functions in the system menu by following the directions on pages 17-29.

**5-Pin XLR DMX Connectors.** Some manufactures use 5-pin DMX-512 data cables for DATA transmission in place of 3-pin. 5-pin DMX fixtures may be implemented in a 3-pin DMX line. When inserting standard 5-pin data cables in to a 3-pin line a cable adaptor must be used, these adaptors are readily available at most electric stores. The chart below details a proper cable conversion.

3-Pin XLR to 5-Pin XLR Conversion		
Conductor	3-Pin XLR Female (Out)	5-Pin XLR Male (In)
Ground/Shield	Pin 1	Pin 1
Data Compliment (- signal)	Pin 2	Pin 2
Data True (+ signal)	Pin 3	Pin 3
Not Used		Pin 4 - Do Not Use
Not Used		Pin 5 - Do Not Use

0	ADDR	AXXX	A001		Indicate the starting DMX address A001 also is the setting for slave	
1	TEST	T-01~T-XX			Automatically test the function	
2	PLAY	RUN		MSTR/ALON	Runs fixture as "master" or "alone" for auto	
		AUDI		MSTR/ALON	Runs fixture as "master" or "alone" for audio	
		AUTO		Clos/Hold/Auto/Audi	Runs fixture for no DMX	
3	LAMP	ON/OFF			Manually switches lamp "on" and "off"	
4	RESE	ALL			Reset all motors and returns fixture to home	
		SCAN			Reset only motors for pan/tilt	
		COLR			Reset only motors for colors	
		GOBO			Reset only motors for gobo and rotation	
		SHTR			Reset only motors for shutter and/or dimmer	
		OTHR			Reset other motors	
5	TIME	LIFE		0000~9999	Displays the total fixture running time	
		LAMP		0000~9999	Displays a lamps running time	
		CLMP			Clear lamp running time	
6	RPAN	ON/OFF			Reverses the pan movements	
7	RTL	ON/OFF			Reverses the tilt movements	
8	FINE	ON/OFF			Switch between 16 bit/8 bit	
9	DEGR	630/540			Pan degree select	
10	MIC	M-XX			Mic sensitivity	
11	DISP	VALU		D-XX D-00 (DXXX)	Display the DMX512 value of each channel	
		D ON		ON/OFF	Display turn off after 2mins	
		FLIP		ON/OFF	This function will reverse the display 180	
12	SPEC	LAAU		ON/OFF	Automatic lamp start with power	
		RDMX		ON/OFF	Change DMX address via external controller	
		DLOF		ON/OFF	Switch lamp via DMX	
		DLAY		D-XX D-05	Lamp on delay time	
		SPOT		ON/OFF	Lamp optimization	
		DFSE		ON/OFF	Resets all the fixture functions to default	
		FEED		ON/OFF	Pan/tilt feedback (error correction) on/off	
		SPEE		SP-1/SP-2	Movement Mode Select	
		DIMM		Slow/Fast	Dimmer speed	
		FANS		HIGH/AUTO	Fan's mode select	
		VER		V1.0~V9.9	Software version	
		ADJU		CODE	CXXX	Fixture code *code is "C050"
				CH01~CH30	XXXX(-128~127)	Motor Calibration
13	EDIT	STEP		S-01 ~S-48	Set the amount of your program	
		SCXX		C-01~C-30	01 XX(00~FFH) 30 XX(00~FFH)	Edit the channels of each scene
			TIME		T XXX(001~999)	Time for each scene
			CEDT		ON/OFF	Edit program via controller
		REC.		RE.XX		Auto Save
		RUN		ON/OFF		Program test

**Operating Modes:** The Accu Spot 575 can operate in three different modes. This next section will detail the differences in the operating modes.

• **Stand alone mode -**

The unit will react to sound, or chase through the built-in programs.

• **Master/Slave mode -**

You can daisy chain up to 16 units together to get a synchronized light show without the need of an external controller. The units will react to sound or chase through the built-in programs.

• **DMX control mode -**

This function will allow you to control each individual fixtures traits with a standard DMX-512 controller such as the Elation® Show Designer.™

**Universal DMX Control:** This function allows you to use a universal DMX-512 controller such as the Elation® DMX Operator™ or Elation® Show Designer™ to control head movement, the color wheel, gobo wheel, prism, and the shutter (strobe). A DMX controller allows you to create unique programs tailored to your individual needs.

1. The Accu Spot 575 uses sixteen DMX channels. See pages 42-46 for detailed description of the DMX traits.
2. To control your fixture in DMX mode, follow the set-up procedures on pages 10-12 as well as the set-up specifications that are included with your DMX controller.
3. Use the controller's faders to control the various DMX fixture traits.
4. This will allow you to create your own programs.
5. Follow the instruction on page 16 to set the DMX address.
6. For longer cable runs (more than a 100 feet) use a terminator on the last fixture.
7. For help operating in DMX mode consult the manual included with your DMX controller.

**02Er – TILT movement error:**

If the head is not located in the default tilt position after start-up or after a reset command. This message will appear after a fixture reset, if the tilt magnetic-indexing circuit malfunctions (sensor failed or magnet is missing) or there is a stepper motor failure (defective motor or a defective motor IC drive on the main PCB).

**03Er - Color-wheel error:**

If the color wheel is not located in the default position after start-up or after a reset command. This message will appear after a fixture reset, if the color wheel's magnetic-indexing circuit malfunctions (sensor failed or magnet is missing) or there is a stepper motor failure (defective motor or a defective motor IC drive on the main PCB).

**04Er - Rotating gobo-wheel error:**

If the gobo-wheel is not located in the default position after start-up or after a reset command. This message will appear after a fixture reset, if the gobo wheel's magnetic-indexing circuit malfunctions (sensor failed or magnet is missing) or there is a stepper motor failure (defective motor or a defective motor IC drive on the main PCB).

**ADDRESS MENU -**

**ADDR** - **ADDR** (Value) - This is where you set the DMX address of the unit.

**TEST MENU -**

**TEST** - **TEST** (Test) - Tests the functions of each channel. There are sixteen channels. **Note: Some channels cannot be tested.**

**PLAY MENU -**

**RUN** - Runs the unit as a “master” or in a stand alone mode. The unit will run a internal program mode.

**AUDI** (Audio) - Runs the unit as a “master” or in a stand alone, sound active mode.

**AUTO** - This is a precaution mode in case the DMX signal is lost. There are four settings to choose from:

- “Hold” - This is the default setting, which in case the signal is lost the fixture will “hold” at the last setting.
- “Close” - The fixture will return to its “home” standing.
- “Auto” - The fixture will go into Auto mode and run a pre-programmed show.
- “Audi” - The fixture will go into Sound Active mode.

**LAMP MENU -**

**ON/OFF** - Manually switch the lamp “on” and “off”.

**RESE (RESET) MENU -**

**ALL** - Resets all the motors in the unit.

**SCAN** - Resets the motors that control pan/tilt.

**COLR** (Color) - Resets the color motors.

**GOBO** - Resets the gobo motors.

SHTR - Resets the shutter/dimmer motors.

OTHR - Resets all other motors.

### **TIME MENU -**

LIFE - Displays the fixtures total running time.

LAMP - Displays the lamp running time.

CLAMP - Clears the lamp running time.

### **RPAN (REVERSE PAN) MENU -**

ON/OFF - When "On" is chosen it will reverse the pan.

### **RTILT (REVERSE TILT) MENU -**

ON/OFF - When "On" is chosen it will reverse the tilt.

### **FINE MENU -**

ON/OFF - Switch between 8bit and 16bit.

### **DEGR MENU -**

630/540 - Switch the degree of the Pan between 630 and 540.

### **MIC MENU -**

01-07 - With this function you can make the internal mic more or less sensitive to sound.

### **DISPLAY MENU -**

VALU (DMX-512 Value) - Display the DMX-512 value of each channel.

ON (Display On) - Turns digital display on or off.

FLIP - "Flips" the digital display 180°.

### **SPEC MENU -**

LAMP - Automatic lamp start with power.

RDAX - Lets you adjust the DMX address via external controller.

LOF - Switch lamp on via DMX.

LAY - Set a delay time for the lamp.

SPOT - This provides a spot beam for better lamp optimization.

When power is applied, the unit will automatically enter a "reset/test" mode. This mode brings all the internal motors to a home position. If there is an internal problem with one or more of the motors an error code will flash in the display in the form of "XXer", "XX" will represent a function number. For example, when the display shows "02Er," it means there is some type of error with the channel 2 motor. If there are multiple errors during the start-up process they will all flash in the display. For example: if the fixtures has errors on channel 1, channel 2, and channel 3 all at the same time, you will see the error message flash "01Er", "02Er," and "03Er" repeated 5 times.

If an error does occur during the initial start-up procedure the fixture will self-generate a second reset signal and try to realign all the motors and correct the errors, if the errors persist after a second attempt a third attempt will be made.

If after a third attempt all the errors have not been corrected the fixture will make the following determinations:

- 1) 3 or more errors - The fixture cannot function properly with three or more errors therefore the fixture will place itself in a stand-by mode until subsequent repairs can be made.
- 2) Less than 3 errors - If the fixture has less than 3 errors, therefore most other functions will work properly. The fixture will attempt to operate normally until the errors can be corrected by a technician. The errors in question will remain flashing in the display as a reminder of internal errors.

01Er – PAN movement error:

If the yoke is not located in the default position after start-up or after a reset command. This message will appear after a fixture reset, if the pan-yoke's magnetic-indexing circuit malfunctions (sensor failed or magnet is missing) or there is a stepper motor failure (defective motor or a defective motor IC drive on the main PCB).



***Editing procedure 3: Record the selected scenes automatically from external controller:***

1. Access the main menu.
2. Select "EDIT" by pressing the UP or DOWN buttons, press ENTER.
3. Press the UP button until the display shows "STEP", press ENTER.
4. Now adjust and set the number of steps by pressing the UP or DOWN buttons. Press ENTER to confirm the number of steps, and "PRESS" will display briefly.
5. Now press the DOWN button until "REC" is displayed, and press ENTER.
6. The display will now show "RE.XX", "XX" stands for the scene number in the internal memory which the scenes from the controller will be stored to. Press ENTER when you have chosen the scene number.
7. Call up the scenes on the controller, and the fixture will record the scenes from the controller automatically. After the number of scenes as selected in the "STEP" menu are loaded into the fixture, it will stop the procedure and return to the previous menu.
8. Press MODE/ESC to exit the "EDIT" menu and return to the main menu.

DFSE (Default Settings) - Resets the unit to the default settings.

FEED - Pan/Tilt feedback (error correction) on/off.

SPEE - Select the movement mode.

DIMM - Select the dimmer speed.

FRNS - Select the fan run mode .

VER (Version) - Displays the software version

ADJ - Calibration functions

***EDIT MENU -***

STEP (S-01 - S-48) - These are the steps slots that you write your programs into. There are a total of 48 steps. See edit program, page 25.

SCXX (SC01 - SC30) - These are the scenes that are stored in your program. There are a total of 30 scenes.

C-XX (C-01 - C-08) - These are the channels of each scene that can be edited..

TIME (Time) - Running time of the entire program.

EDIT - Edit a program using a external controller.

REC - This will auto save your custom program.

RUN - This will run your custom program.

**On-Board System Menu.** The Accu Spot 575 comes with an easy to navigate system menu. This next section will detail the functions of each command in the system menu.

**Enter Button** - To access the main menu locate the ENTER button (7) on the side of the unit. Press this button to activate the system menu. Tap the UP (5) or DOWN (6) buttons until you reach function you wish to change. When you reach the function you wish to change tap the ENTER button. When a function is selected the menu will begin to flash, use the UP or DOWN buttons to change the function. Once your changes are made tap the ENTER button again to lock the change in the system, if the ENTER button is not selected within eight seconds the system will automatically return to menu section. To exit without making any changes tap the MODE/ESC button (4).

## ADDR MAIN MENU -

### ADDR DMX Address Setting via control board -

1. Access the main menu.
2. Tap the UP button until "ADDR" is displayed, press ENTER.
4. Now the display will show "ADDR". Adjust the DMX address by pressing the UP or DOWN buttons.
5. Press ENTER to confirm.
6. Press the MODE/ESC button to return to the main menu.

**When the display is on "ADDR", you can directly press the UP or DN buttons to change the DMX start address.**

## TEST MAIN MENU -

### TEST - This will test the functions of each channel.

1. Access the main menu.
2. Tap the UP button until "TEST" is displayed, press ENTER.
3. The display will show "T-01". You can now press the up

13. Repeat steps 3-12 to edit other scenes, you can edit and save 48 scenes maximum.

14. Press MODE/ESC to exit, now you have edited and saved scenes using the control board. The number of steps can be defined under "Step" and the scenes can be called up under "Run". To run the scenes see page 17.

### **Editing procedure 2: Using an external controller (Manually record scenes one by one):**

1. Access the main menu.
2. Select "EDIT" by pressing the UP or DOWN buttons, press ENTER.
3. The display shows "SC01".
4. Press ENTER, and the display shows "C-01".
5. Select "EDIT" by pressing the DOWN button, and press ENTER.
6. The display "OFF", press the UP button so that "ON" is displayed, and press ENTER.
7. The display will show "SC02". You have now successfully downloaded the first scene.
8. Adjust the Step-time needed by pressing the UP button.
9. Call up the second scene in your controller now.
10. Repeat steps 7-9 until all desired scenes are downloaded.
11. Press MODE/ESC to exit. The number of steps can be defined under "Step" and the scenes can be called up under "Run".

**Editing procedure 1: Using the control board only.**

1. Access the main menu.
2. Tap the UP button until "EDIT" is displayed. Press ENTER.
3. The display will show "SCXX", the "X" again stands for the scene number. For example, "SC01" is displayed, it means you will be editing scene 1, press ENTER. You can change the scene number by pressing the UP button.
4. Press ENTER, the display will show "C-X", the "X" again stands for the channel number. If "C-01" is displayed, you will be editing channel 1 of your selected scene, press ENTER. You can change the channel number by pressing the UP button.
5. The display will show the DMX value for the channel that is being edited. It will be displayed as "11XX", it stands for Channel 11 of the editing scene, the DMX value is "XX".
6. Adjust the DMX value by pressing the UP button, until you get the expected effect for this channel.
7. Press ENTER to enter the editing of the other channels of the scene.
8. Repeat steps 5-8, until you finish setting all the DMX values for all the channels of this scene, each scene can have 15 channels maximum.
9. Once all the channels are completed, the display will flash "TIME", this stands for the time needed to run this scene.
10. Press ENTER to edit the time needed, the display shows "TXX", "X" stands for the time needed to run this scene. For example, "T002" means scene 1 needs 0.4 seconds to run, "T015" means scene 1 needs 3 seconds to run.
11. Adjust the time needed by pressing the UP button.
12. Press ENTER to save the settings for the scene you are editing, the display will change to the next scene automatically.

button and test the different channels.

4. Press MODE/ESC to exit.

**PLAY MAIN MENU -**

**RUN** Run the unit as a "master", or as a stand alone unit, using a internal program -

1. Access the main menu.
2. Tap the UP button until "PLAY" is displayed, press ENTER.
3. Tap the UP or DOWN button to choose between "MASTER" or "ALONE", select your choice and press ENTER.
4. Press MODE/ESC to return to the main menu.

**AUDI** Run the unit as a "master", or as a stand alone unit, in a sound active mode -

1. Access the main menu.
2. Tap the UP button until "PLAY" is displayed, press ENTER.
3. Tap the UP or DOWN button to choose between "MASTER" or "ALONE", select your choice and press ENTER.
4. Press MODE/ESC to return to the main menu.

**AUTO** This is a precaution mode in case you lose the DMX signal. The fixture has 4 modes to choose from, please see page 14 for a description of the 4 modes -

1. Access the main menu by pressing MODE/ESC button.
2. Tap the UP button until "PLAY" is displayed, press ENTER.
3. Tap the UP button until "AUTO" is displayed, press ENTER.
4. Now you can choose between "CLOSE", "HOLD" "AUTO", or

“AUDI”. “HOLD” is the default setting.

5. Select the mode that you want the fixture to run in case of a lost DMX signal and press ENTER.

### LAMP MAIN MENU -

**ON/OFF** - With this function you can manually switch the lamp on and off.

1. Access the main menu.
2. Tap the UP button until “LAMP” is displayed, press ENTER.
3. Press the UP or DOWN buttons to select either “ON” to activate this function, or “OFF” to deactivate this function.
4. Press ENTER to confirm.
5. Press MODE/ESC to return to the main menu.

### RESE MAIN MENU -

**ALL** - When you activate the reset function, the fixture will begin the reset motion.

1. Access the main menu.
2. Tap the UP button until “RESE” is displayed, press ENTER.
3. Tap the UP button until “ALL” is displayed.
4. Press ENTER to reset all motors, or press MODE/ESC to cancel and return to the main menu.

**SCAN** - When you activate this reset function, the fixture will only reset the pan/tilt motor.

1. Access the main menu.
2. Tap the UP button until “RESE” is displayed, press ENTER.

2. Tap the UP button until “EDIT” is displayed, press ENTER.
3. Tap the UP button until “REC” is displayed.
4. The display shows “RE.XX”, “XX” stands for the scene number in the internal memory of where your scenes from the controller will be stored.
5. Press the UP or DOWN button to select your desired scene number.
6. Press ENTER to confirm, and the fixture will record the scenes from the external controller.
7. Press MODE/ESC to return to the main menu.

**RUN** With the function “RUN”, you can run your pre-made program. You can set the number of steps under Step (S-01 - S-48). You can edit the individual scenes under Edit.

1. Access the main menu.
2. Tap the UP button until “EDIT” is displayed, press ENTER.
3. Tap the UP button until “RUN” is displayed, press ENTER.
4. Press the UP button, to select either “ON” or “OFF”.
5. Select a mode, and press ENTER to confirm.
6. Press MODE/ESC to return to the main menu.

**EDIT** - This menu item allows you to write a program into the memory (EEPROM) via the control panel or via the external controller. *Please see pages 32-34 for detailed instructions.*

**STEP** - With this function you can program the number of steps in your individual Program.

1. Access the main menu.
2. Tap the UP button until “EDIT” is displayed, press ENTER.
3. Tap the UP button until “STEP” is displayed, press ENTER.
4. The display shows “5-01”, this stands for the first step of your program. You can call up to 48 scenes in “Run”. For example, if “5-05” is displayed, it means that “Run” will run the first 5 scenes you saved in “Edit”.
5. Press ENTER to save and press MODE/ESC to exit.

**SC01** - With this function you can choose the number of scenes in your Program.

1. Access the main menu.
2. Tap the UP button until “EDIT” is displayed, press ENTER.
3. Tap the UP button until “SC01” is displayed.
4. The display shows “SC01”, this stands for the first scene of your program. You can call up to 48 scenes. For example, if “SC05”, it means that “Run” will run the first 5 scenes you saved in “Edit”.
5. Press ENTER to save and press MODE/ESC to exit.

**REC** - With this function you can record the scenes automatically for the external controller.

1. Access the main menu.

3. Tap the UP button until “SCAN” is displayed.

4. Press ENTER to reset the pan/tilt motors, or press MODE/ESC to cancel and return to the main menu.

**COLR** - When you activate this reset function, the fixture will only reset the color wheel motor.

1. Access the main menu.
2. Tap the UP button until “RESE” is displayed, press ENTER.
3. Tap the UP button until “COLR” is displayed.
4. Press ENTER to reset the color wheel motor, or press MODE/ESC to cancel and return to the main menu.

**GOBO** - When you activate this reset function, the fixture will only reset the gobo wheel motor.

1. Access the main menu.
2. Tap the UP button until “RESE” is displayed, press ENTER.
3. Tap the UP button until “GOBO” is displayed.
4. Press ENTER to reset the gobo wheel motor, or press MODE/ESC to cancel and return to the main menu.

**SHTR** - When you activate this reset function, the fixture will only reset the shutter/dimmer motor.

1. Access the main menu.
2. Tap the UP button until “RESE” is displayed, press ENTER.
3. Tap the UP button until “SHTR” is displayed.
4. Press ENTER to reset the shutter/dimmer motor, or press MODE/ESC to cancel and return to the main menu.

**OTHR** - When you activate this reset function, the fixture will reset all other motors that are not listed in RESET

**menu.**

1. Access the main menu.
2. Tap the UP button until "RESE" is displayed, press ENTER.
3. Tap the UP button until "OTHR" is displayed.
4. Press ENTER to reset all other motors, or press MODE/ESC to cancel and return to the main menu.

**TIME MAIN MENU -****LIFE - With this function you can display the total running time of the unit.**

1. Access the main menu.
2. Tap the UP button until "TIME" is displayed, press ENTER.
3. Tap the UP button until "LIFE" is displayed, press ENTER.
4. Press MODE/ESC to return to the main menu.

**LAMP - With this function you can display the running time of the lamp.**

1. Access the main menu.
2. Tap the UP button until "TIME" is displayed, press ENTER.
3. Tap the UP button until "LAMP" is displayed, press ENTER.
4. Press MODE/ESC to return to the main menu.

**CLMP - With this function you can clear the running time of the lamp. Note Very Important: Please clear the lamp time every time you replace the lamp.**

1. Access the main menu.
2. Tap the UP button until "TIME" is displayed, press ENTER.

4. The display will show "V-1.0", the display may also show, "V-2.0", "V-9.9" etc.
5. Press MODE/ESC to exit.

**ADJU - Use this function is used to make sure all motors are aligned and to adjust any motors that are not.**

1. Access the main menu.
2. Tap the UP button until "SPEC" is displayed, press ENTER.
3. Tap the UP button until "ADJU" is displayed, press ENTER.
4. Tap the UP button until "CODE" is displayed, press ENTER.
5. The display will show "CXXX", were as "XXX" represents the calibration password. The calibration password is "C050." Use the UP or DOWN buttons to enter the proper password.
6. Once the proper password is entered the display will read "CHXX", were as "XX" represents the fixture channel number, in the case of the Accu Spot 575 1 ~ 16.
7. Select the desired channel to be calibrated by pressing the UP or DOWN buttons and then ENTER to confirm.
8. The display will then read "XXXX", were "XXXX" stands for the calibrate values.
9. Adjust the desired calibration value between -128 and 127 by pressing the UP and DOWN. As you scroll up and down through the calibration values you will notice slight changes in the wheel or motor you are attempting to calibrate.
10. Once you reach your desired calibration press ENTER to confirm and lock in your calibration.
11. Once you are completely finished press MODE/ESC to return to the main menu.

4. Press the UP or DOWN buttons to select either “SP-1” or “SP-2”.
5. Press ENTER to select your desired mode.

### **DIMM** - With this function you can control the dimmer speed

1. Access the main menu.
2. Tap the UP button until “SPEC” is displayed, press ENTER.
3. Tap the UP button until “DIMM” is displayed, press ENTER.
4. Press the UP or DOWN buttons to select either “SLOW” or “FAST”.
5. Press ENTER to select your desired mode.

### **FANS** - With this function you can choose between the two fan functions.

1. Access the main menu.
2. Tap the UP button until “FANS” is displayed, press ENTER.
3. Press the UP or DOWN buttons to select either “HIGH” or “AUTO”.
4. Press ENTER to confirm your selection.
5. Press MODE/ESC to return to the main menu.

### **VER** - Use this function to display the Software version of the unit.

1. Access the main menu.
2. Tap the UP button until “SPEC” is displayed, press ENTER.
3. Tap the UP button until “VER” is displayed, press ENTER.

3. Tap the UP button until “CLIP” is displayed, press ENTER.
4. Press ENTER to confirm.
5. Press MODE/ESC to return to the main menu.

### **RPAN MENU** -

#### **RPAI** - The movement of the Pan will be reversed.

1. Access the main menu.
2. Tap the UP button until “RPAN” is displayed, press ENTER.
3. Press the UP or DOWN buttons to select either “ON” to activate this function, or “OFF” to deactivate this function.
4. Press ENTER to confirm.
5. Press MODE/ESC to return to the main menu.

### **RTILT MENU** -

#### **RTIL** - The movement of the Tilt will be reversed.

1. Access the main menu.
2. Tap the UP button until “RTILT” is displayed, press ENTER.
3. Press the UP or DOWN buttons to select either “ON” to activate this function, or “OFF” to deactivate this function.
4. Press ENTER to confirm.
5. Press MODE/ESC to return to the main menu.

### **FINE MENU** -

#### **FINE** - This function will switch the pan/tilt between 8bit and 16bit.

1. Access the main menu.

3. Tap the UP button until "FINE" is displayed, press ENTER.
4. Press the UP or DOWN buttons to select either "ON" to activate this function, or "OFF" to deactivate this function.
5. Press ENTER to confirm.
6. Press MODE/ESC to return to the main menu.

### DEGR MENU -

#### DEGR - With this function you can switch the Pan degree.

1. Access the main menu.
2. Tap the UP button until "DEGR" is displayed, press ENTER.
3. Press the UP or DOWN buttons to select either "630" or "540".
4. Press ENTER to confirm your selection.
5. Press MODE/ESC to return to the main menu.

### MIC MENU -

#### MIC - The internal microphone can be made more or less sensitive.

1. Access the main menu.
3. Tap the UP button until "MIC" is displayed, press ENTER.
4. The display will show "1-01".
5. Press the UP or DOWN button to adjust the microphone sensitivity between "1-01 - 1-99".
6. Press ENTER to confirm when you have reached your desired microphone sensitivity level.
7. Press MODE/ESC to return to the main menu.

2. Tap the UP button until "SPEC" is displayed, press ENTER.
3. Tap the UP button until "OFFSE" is displayed, press ENTER.
4. The display will show "ON/OFF".
5. Press the UP button to display "ON" to activate this function, or "OFF" to deactivate this function.
6. Press ENTER to confirm.
7. Press MODE/ESC to return to the main menu.

***When you exit this function, the unit will begin to reload data.***

#### FEED - With this function you can switch the Pan/Tilt error correction on and off. This will automatically correct the Pan/Tilt if it is somehow moved out of place.

1. Access the main menu.
2. Tap the UP button until "SPEC" is displayed, press ENTER.
3. Tap the UP button until "FEED" is displayed, press ENTER.
4. Press the UP or DOWN buttons to select either "ON" to activate this function, or "OFF" to deactivate this function.
5. Press ENTER to confirm.
6. Press MODE/ESC to return to the main menu.

#### SPEE - With this function you can select the movement mode

1. Access the main menu.
2. Tap the UP button until "SPEC" is displayed, press ENTER.
3. Tap the UP button until "SPEE" is displayed, press ENTER.



**DELAY** - With this function you can set a lamp delay time.

1. Access the main menu.
2. Tap the UP button until "SPEC" is displayed, press ENTER.
3. Tap the UP button until "DELAY" is displayed, press ENTER.
4. The display should show "0-00". Press the UP button in order to select your desired delay time.
5. Press ENTER to confirm.
6. Press MODE/ESC to return to the main menu.

**SPOT** - With this function you can adjust the lamp via the control board. The shutter opens and the lamp can be adjusted. In this mode, the device will not react to any control signal.

1. Access the main menu.
2. Tap the UP button until "SPEC" is displayed, press ENTER.
3. Tap the UP button until "SPOT" is displayed, press ENTER.
4. Press the UP or DOWN buttons to select either "ON" to activate this function, or "OFF" to deactivate this function.
5. Press ENTER to confirm.
6. Press MODE/ESC to return to the main menu.

**DFSE** - With this function you can restore the factory settings of the device. All settings will be set back to the default values. Any edited scenes will be lost. When restoring the factory settings the unit must be set to the address that the unit was in when you started editing.

1. Access the main menu.

**DISP MAIN MENU** -**VALU** Display the DMX-512 value of each channel -

1. Access the main menu.
2. Tap the UP button until "DISP" is displayed, press ENTER.
3. Tap the UP button until "VALU" is displayed, press ENTER.
4. The display should show "0-00". Press the UP button in order to select the desired channel. If you select "0-05" the display will only show the DMX value of the 5th channel
5. Press ENTER to confirm.
6. Press MODE/ESC to return to the main menu.

**Now the display will change as per the 5th channel DMX value.**

**ON** Turns the digital display on and off -

1. Access the main menu.
2. Tap the UP button until "DISP" is displayed, press ENTER.
3. Tap the UP button until "ON" is displayed, press ENTER.
4. Press the UP or DOWN buttons to select either "ON" to activate this function, or "OFF" to deactivate this function.
5. Press ENTER to confirm.
6. Press MODE/ESC to return to the main menu.

**FLIP** - This function will reverse the display 180°.

1. Access the main menu.
2. Tap the UP button until "DISP" is displayed.

3. Tap the UP button until "FLIP" is displayed, press ENTER.
4. Press the UP or DOWN buttons to select either "ON" to activate this function, or "OFF" to deactivate this function.
5. Press ENTER to confirm.
6. Press MODE/ESC to return to the main menu.

### SPEC MAIN MENU -

**LAMP** - With this function the lamp will automatically light when power is applied.

1. Access the main menu.
2. Tap the UP button until "SPEC" is displayed, press ENTER.
3. Tap the UP button until "LAMP" is displayed, press ENTER.
4. Press the UP or DOWN buttons to select either "ON" to activate this function, or "OFF" to deactivate this function.
5. Press ENTER to confirm.
6. Press MODE/ESC to return to the main menu.

**DMX** With this function you are able to change the DMX address via any DMX controller. This function is factory set to "ON" already.

1. Access the main menu by pressing MODE/ESC.
2. Tap the UP button until "SPEC" is displayed, press ENTER.
3. Tap the UP button until "DMX" is displayed, press ENTER.
4. Press the UP button to select "ON" to activate this function, or "OFF" to deactivate.
5. Press ENTER to confirm, and "PASS" will flash quickly.
6. Press MODE/ESC to return to the main menu.

**To use this function follow the instructions:**

To adjust the address of your unit you must first go to the address that it is currently set to. From there you can adjust the address. First make sure all channels are set to the value of "0".

1. On your DMX controller set the DMX value of Channel 1 to the value "7".
2. Now set the DMX value of Channel 2 to the value "7" to adjust the starting address between 1 and 255. To adjust the address between 256 and 511 set Channel 2 to the value "8".
3. Set the DMX value of Channel 3 to your desired starting address. This will take about 20 seconds before the unit accepts the new DMX address.

**EXAMPLE:** So, if you want the address to be 57, you must first set the address that is currently assigned to the unit. The proceed to set Channel 1s' value to "7", Channel 2s' value to "7", and Channel 3s' value to "57".

**2ND EXAMPLE:** Again, if you want the address to be 420, you must first set the address that is currently assigned to the unit. If you want the set the address to 420, set Channel 1s' value to "7", Channel 2s' value to "8", and Channel 3s to "164". (256 + 164 = 420)

**DMX** - With this function you can switch the lamp on via DMX.

1. Access the main menu.
2. Tap the UP button until "SPEC" is displayed, press ENTER.
3. Tap the UP button until "DMX" is displayed, press ENTER.
4. Press the UP or DOWN buttons to select either "ON" to activate this function, or "OFF" to deactivate this function.
5. Press ENTER to confirm.
6. Press MODE/ESC to return to the main menu.