

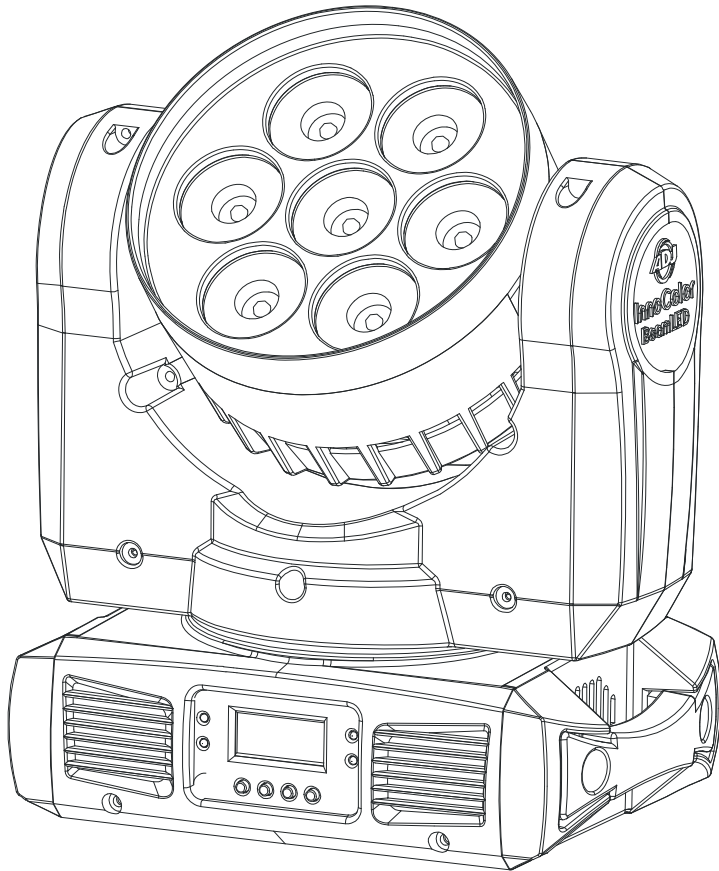

## INNO COLOR BEAM QUAD 7



### *User Instructions*

©2013 ADJ Products, LLC all rights reserved. Information, specifications, diagrams, images, and instructions herein are subject to change without notice. ADJ Products, LLC logo and identifying product names and numbers herein are trademarks of ADJ Products, LLC. Copyright protection claimed includes all forms and matters of copyrightable materials and information now allowed by statutory or judicial law or hereinafter granted. Product names used in this document may be trademarks or registered trademarks of their respective companies and are hereby acknowledged. All non-ADJ Products, LLC brands and product names are trademarks or registered trademarks of their respective companies.

**ADJ Products, LLC** and all affiliated companies hereby disclaim any and all liabilities for property, equipment, building, and electrical damages, injuries to any persons, and direct or indirect economic loss associated with the use or reliance of any information contained within this document, and/or as a result of the improper, unsafe, insufficient and negligent assembly, installation, rigging, and operation of this product.

Europe Energy Saving Notice

Energy Saving Matters (EuP 2009/125/EC)

Saving electric energy is a key to help protecting the environment. Please turn off all electrical products when they are not in use. To avoid power consumption in idle mode, disconnect all electrical equipment from power when not in use. Thank you!

## Inno Color Beam Quad 7

## Introduction

**Unpacking:** Thank you for purchasing the Inno Color Beam Quad 7 by ADJ Products, LLC. Every Inno Color Beam Quad 7 has been thoroughly tested and has been shipped in perfect operating condition. Carefully check the shipping carton for damage that may have occurred during shipping. If the carton appears to be damaged, carefully inspect your fixture for any damage and be sure all accessories necessary to operate the unit has arrived intact. In the case damage has been found or parts are missing, please contact our toll free customer support number for further instructions. Do not return this unit to your dealer without first contacting customer support.

**Introduction:** The Inno Color Beam Quad 7 is part of ADJ's continuing pursuit for creating high quality affordable intelligent fixtures. The Inno Color Beam Quad 7 is a high performance, DMX intelligent, moving head LED fixture. This fixture is a great piece for retail stores, displays, mood, architectural, interior and exterior decoration, and clubs. This unit can be used as a stand alone, or in a Master/Slave configuration. The unit can also be controlled via DMX controller. This fixture is suitable for theaters, studios, retail stores, and other similar locations.

**Customer Support:** ADJ Products, LLC provides a toll free customer support line, to provide set up help and to answer any question should you encounter problems during your set up or initial operation. You may also visit us on the web at [www.adj.com](http://www.adj.com) for any comments or suggestions. Service Hours are Monday through Friday 8:00 a.m. to 4:30 p.m. Pacific Standard Time.

Voice: (800) 322-6337

Fax: (323) 582-2941

E-mail: [support@americandj.com](mailto:support@americandj.com)

**Warning!** To prevent or reduce the risk of electrical shock or fire, do not expose this unit to rain or moisture.

**Caution!** There are no user serviceable parts inside this unit. Do not attempt any repairs yourself, doing so will void your manufactures warranty. In the unlikely event your unit may require service please contact ADJ Products, LLC.

**PLEASE recycle the shipping carton when ever possible.**

## Inno Color Beam Quad 7

## General Instructions

To optimize the performance of this product, please read these operating instructions carefully to familiarize yourself with the basic operations of this unit. These instructions contain important safety information regarding the use and maintenance of this unit. Please keep this manual with the unit, for future reference.

## Inno Color Beam Quad 7

## Features

- RGBW Color Mixing
- 7 x 10W High Quality CREE LEDs
- Strobe Effect
- Color Mix Effect
- Pan/Tilt Inversion
- Electronic Dimming 0-100%
- Dimmer Curve
- Built in Microphone
- DMX-512 protocol
- Two DMX Modes: 1 Channel Mode & 13 Channel Mode
- 3 Operating Modes - Sound Active, Show Mode, or DMX Control
- UC3 Remote Control Compatible (Not Included)
- Power Cord Daisy Chaining (See Page 19)

## Inno Color Beam Quad 7

## Warranty Registration

The Inno Color Beam Quad 7 carries a 3 year (1095 days) limited warranty. Please fill out the enclosed warranty card to validate your purchase and warranty. You may also register your product online at [www.americandj.com](http://www.americandj.com). All returned service items whether under warranty or not, must be freight pre-paid and accompany a return authorization (R.A.) number. If the unit is under warranty you must provide a copy of your proof of purchase invoice. Please contact ADJ customer support for a R.A. number.

- To reduce the risk of electrical shock or fire, do not expose this unit rain or moisture
- Do not spill water or other liquids into or on to your unit.
- Be sure that the local power outlet match that of the required voltage for your unit.
- Do not attempt to operate this unit if the power cord has been frayed or broken. Do not attempt to remove or break off the ground prong from the electrical cord. This prong is used to reduce the risk of electrical shock and fire in case of an internal short.
- Disconnect from main power before making any type of connection.
- Do not remove the cover under any conditions. There are no user serviceable parts inside.
- Never operate this unit when it's cover is removed.
- Never plug this unit in to a dimmer pack
- Always be sure to mount this unit in an area that will allow proper ventilation. Allow about 6" (15cm) between this device and a wall.
- Do not attempt to operate this unit, if it becomes damaged.
- This unit is intended for indoor use only, use of this product outdoors voids all warranties.
- During long periods of non-use, disconnect the unit's main power.
- Always mount this unit in safe and stable matter.
- Power-supply cords should be routed so that they are not likely to be walked on or pinched by items placed upon or against them, paying particular attention to the point they exit from the unit.
- Cleaning -The fixture should be cleaned only as recommended by the manufacturer. See page 19 for cleaning details.
- Heat -The appliance should be situated away from heat sources such as radiators, heat registers, stoves, or other appliances (including amplifiers) that produce heat.
- The fixture should be serviced by qualified service personnel when:
  - A. The power-supply cord or the plug has been damaged.
  - B. Objects have fallen, or liquid has been spilled into the appliance.
  - C. The appliance has been exposed to rain or water.
  - D. The appliance does not appear to operate normally or exhibits a marked change in performance.

**Power Supply:** The ADJ Inno Color Beam Quad 7 contains a automatic voltage switch, which will auto sense the voltage when it is plugged into a power source. With this switch there is no need to worry about the correct power voltage, this unit can be plugged in anywhere.

**DMX-512:** DMX is short for Digital Multiplex. This is a universal protocol used as a form of communication between intelligent fixtures and controllers. A DMX controller sends DMX data instructions from the controller to the fixture. DMX data is sent as serial data that travels from fixture to fixture via the DATA "IN" and DATA "OUT" XLR terminals located on all DMX fixtures (most controllers only have a DATA "OUT" terminal).

**DMX Linking:** DMX is a language allowing all makes and models of different manufactures to be linked together and operate from a single controller, as long as all fixtures and the controller are DMX compliant. To ensure proper DMX data transmission, when using several DMX fixtures try to use the shortest cable path possible. The order in which fixtures are connected in a DMX line does not influence the DMX addressing. For example; a fixture assigned a DMX address of 1 may be placed anywhere in a DMX line, at the beginning, at the end, or anywhere in the middle. When a fixture is assigned a DMX address of 1, the DMX controller knows to send DATA assigned to address 1 to that unit, no matter where it is located in the DMX chain.

**Data Cable (DMX Cable) Requirements (For DMX Operation):**

The Inno Color Beam Quad 7 can be controlled via DMX-512 protocol. The Inno Color Beam Quad 7 can be either a 1 Channel or 13 Channel DMX unit. The DMX address is set on the rear panel of the Inno Color Beam Quad 7. Your unit and your DMX controller require a approved DMX-512 110 Ohm Data cable for data input and data output (Figure 1). We recommend Accu-Cable DMX cables. If you are making your own cables, be sure to use standard 110-120 Ohm shielded cable (This cable may be purchased at almost all professional sound and lighting stores). Your cables should be made with a male and female XLR connector on either end of the cable. Also remember that DMX cable must be daisy chained and cannot be split.



Figure 1

**Notice:** Be sure to follow figures two and three when making your own cables. Do not use the ground lug on the XLR connector. Do not connect the cable's shield conductor to the ground lug or allow the shield conductor to come in contact with the XLR's outer casing. Grounding the shield could cause a short circuit and erratic behavior.

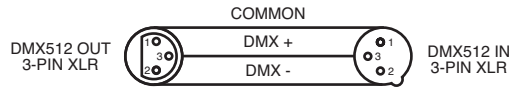

Figure 2

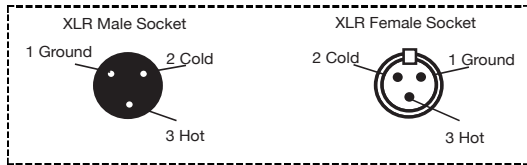

Figure 3

XLR Pin Configuration	
Pin 1 =	Ground
Pin 2 =	Data Compliment (negative)
Pin 3 =	Data True (positive)

**Special Note: Line Termination.** When longer runs of cable are used, you may need to use a terminator on the last unit to avoid erratic behavior. A terminator is a 90-120 ohm 1/4 watt resistor which is connected between pins 2 and 3 of a male XLR connector (DATA + and DATA -). This unit is inserted in the female XLR connector of the last unit in your daisy chain to terminate the line. Using a cable terminator (ADJ part number Z-DMX/T) will decrease the possibilities of erratic behavior.



Termination reduces signal errors and avoids signal transmission problems and interference. It is always advisable to connect a DMX terminal. (Resistance 120 Ohm 1/4 W) between PIN 2 (DMX-) and PIN 3 (DMX +) of the last fixture.

Figure 4

**5-Pin XLR DMX Connectors.** Some manufactures use 5-pin XLR connectors for DATA transmission in place of 3-pin. 5-pin XLR fixtures may be implemented in a 3-pin XLR DMX line. When inserting standard 5-pin XLR connectors in to a 3-pin line a cable adaptor must be used, these adaptors are readily available at most electric stores. The chart below details a proper cable conversion.

3-Pin XLR to 5-Pin XLR Conversion		
Conductor	3-Pin XLR Female (Out)	5-Pin XLR Male (In)
Ground/Shield	Pin 1	Pin 1
Data Compliment (- signal)	Pin 2	Pin 2
Data True (+ signal)	Pin 3	Pin 3
Not Used		Do Not Use
Not Used		Do Not Use

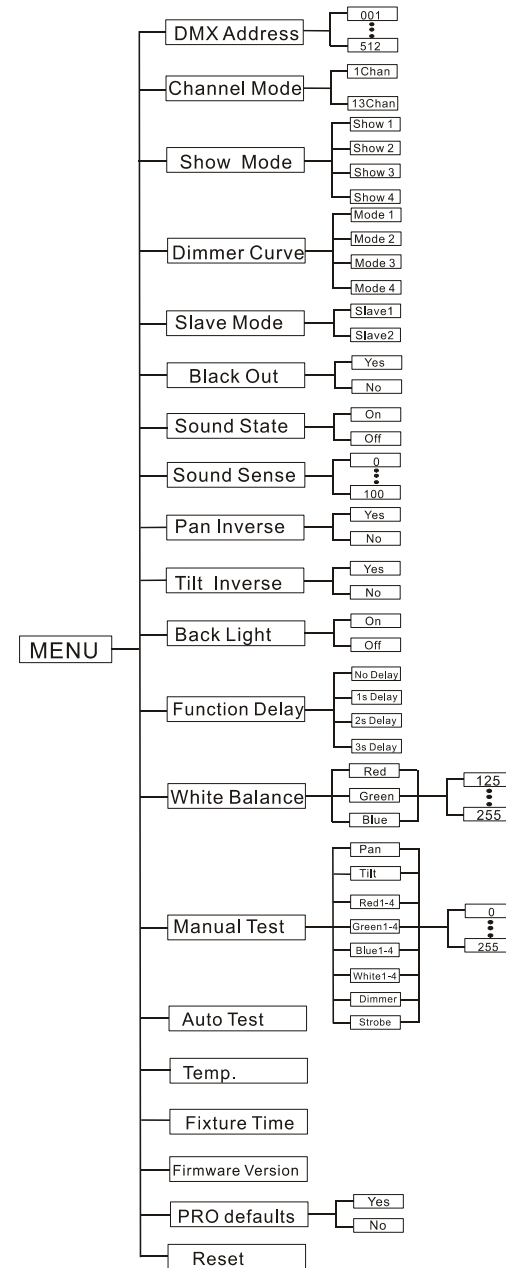

## DMX Address - Set the DMX Address -

1. Press the MENU button until “DMX Address” is displayed, press ENTER.
2. “X” will now be displayed, “X” represents the displayed address. Press the UP or DOWN buttons to find your desired address.
3. Press ENTER to confirm, and then press and hold the MENU button for at least three seconds to assign.

## Channel Mode - This will let you select your desired DMX Channel mode.

1. Press the MENU button until “Channel Mode” is displayed, press ENTER.
2. “X Chan” will now be displayed, “X” represents the displayed DMX channel mode; either 1 Channel Mode or 13 Channel Mode. Press the UP or DOWN buttons to find your desired Channel mode.
3. Press ENTER to confirm.

## Show Mode - Show modes 0 - 4 (Factory Shows).

1. Press the MENU button until “Show Mode” is displayed, press ENTER.
2. “Show X” will now be displayed, “X” representing a number between 1-4. Press the UP or DOWN buttons to find your desired show and press ENTER to confirm.
3. Press and hold the MENU button for at least 3 seconds to activate.

## Dimmer Curve - In this mode you can select the dimmer curve.

1. Press the MENU button until “Dimmer Curve” is displayed, press ENTER.

2. “MODE X” will be displayed, “X” representing the displayed dimmer mode. The modes are explained below.

Dimmer Mode 1 (Linear) - Steady, even increase in dimming.

Dimmer Mode 2 (Square Law) - Provides finer dimming control near full intensity.

Dimmer Mode 3 (Inverse Square Law) - Provides finer dimming control at lower intensities.

Dimmer Mode 4 (S-Curve) - Similar to Linear dimming with finer dimming control at mid level intensities.

3. Press the UP or DOWN buttons to find your desired show mode and press ENTER, then press and hold the MENU button for at least 3 seconds to confirm.

## Slave Mode - This will let you set unit as a master or slave in a master/slave configuration.

1. Press the MENU button until “Slave Mode” is displayed, press ENTER. Either “Slave 1” or “Slave 2” will be displayed.
2. Press the UP or DOWN buttons until your desired slave mode is displayed, press ENTER to confirm.

**NOTE:** In a Master/Slave configuration you can make one fixture the Master and then set the next fixture to “Slave 2”, the fixtures will now have contrast movement to each other.

## Black Out - This will control blackout

1. Press the MENU button until “Black Out” is displayed, press ENTER.
2. Either “Yes” or “No” will now be displayed. Press the UP or DOWN buttons to toggle between “Yes” and “No”.
3. Press ENTER to confirm your setting.



**Sound State - In this mode the unit will run in sound active mode.**

1. Press the MENU button until “Sound State” is displayed, press ENTER.
2. Either “On” or “Off” will now be displayed. Use the UP or DOWN buttons to toggle between “On” and “Off”.
3. Press ENTER to confirm your selection, the press and hold the MENU button to activate.

**Sound Sense - In this mode you can adjust the sound sensitivity of the sound active mode.**

1. Press the MENU button until “Sound Sense” is displayed, press ENTER.
2. Press the UP or DOWN buttons to adjust the sensitivity level. The sensitivity level can be adjusted between 0 (the lowest) and 100 (most sensitive).
3. Press ENTER to set you desired level.

**Pan Inverse - Pan Inversion**

1. Press the MENU button until “Pan Inverse” is displayed, press ENTER. Either “Yes” or “No” will be displayed.
2. To activate the Pan inversion press the UP or DOWN buttons until “Yes” is displayed, press ENTER to confirm. To deactivate Pan inversion, select “No” and press Enter.

**Tilt Inverse - Tilt Inversion**

1. Press the MENU button until “Tilt Inverse” is displayed, press ENTER. Either “Yes” or “No” will be displayed.
2. To activate the Tilt inversion press the UP or DOWN buttons until “Yes” is displayed, press ENTER to confirm. To deactivate Tilt inversion, select “No” and press Enter.

**Back Light - With this function you can make the backlight automatically turn off after one minute.**

1. Press the MENU button until “Back Light” is displayed, press ENTER.
2. Either “ON” or “OFF” will now be displayed. Press the UP or DOWN buttons to select “ON” to keep the backlight on at all times, or “OFF” to allow the backlight to turn off after 2 minutes. Press any button to turn the backlight on again.
3. Press ENTER to confirm.

**Function Delay - With this function the blackout function under 13 Channel mode can be delayed.**

1. Press the MENU button until “Function Delay” is displayed, press ENTER.
2. Either “No Delay” or time between 1s - 3s will be displayed. This number represents the delay setting. Use the UP and DOWN buttons to adjust the blackout delay.  
*Example: If the delay is set to 3 seconds, when you are in 13 Channel mode under DMX control, and the channel 12 values are between 226-235, the fixture will move, and then blackout after 3 seconds.*
3. Press ENTER to confirm.

**White Balance - With this function you can adjust the RGB colors to make your desired color.**

1. Press the MENU button until “White Balance” is displayed, press ENTER.
2. Use the UP or DOWN buttons to find the color you wish to adjust.
3. Once you find the color you want to adjust press ENTER, the displayed value will begin to flash. Use the UP or DOWN but-

tons to adjust the value. Once you have made your adjustment press ENTER.

4. Repeat steps 2-3 until satisfied.

### **Manual Test - With this function you can manually test the individual features.**

1. Press the MENU button until “Manual Test” is displayed, press ENTER.

2. Use the UP or DOWN buttons to find the functions or colors that you wish to test. You can also test the strobe function and dimmer.

3. Once you find a function or color you wish to test, press the ENTER button, the displayed value will begin to flash. You can now adjust the values by pressing the UP and DOWN buttons. Once you have finished testing press the ENTER button.

4. To exit the manual test mode, press the MENU button.

### **Auto Test - This function will run a self test program.**

1. Press the MENU button until “Auto Test” is displayed, press ENTER.

2. The fixture will now run a self test. Press the MENU button to exit.

### **Temp. - With this function you can display the running temperature of the unit.**

1. Tap the MENU button until “Temp.” is displayed, press ENTER.

2. The current running temperature of the fixture will now be displayed. Press MENU to exit.

### **Fixture Time - With this function you can display the running time of the unit.**

1. Tap the MENU button until “Fixture Time” is displayed, press ENTER.

2. The running time of the fixture will now be displayed. Press MENU to exit.

### **Firmware Version - This will display the software version**

1. Tap the MENU button until “Firmware Version” is displayed. Press the ENTER button and the software version will be displayed.

2. Press the MENU button to leave this function.

### **PRO Defaults - Restore all functions to their defaults.**

1. Tap the MENU button until “PRO Defaults” is displayed, press ENTER.

2. Either “YES” or “NO” will now be displayed. Press the UP or DOWN buttons to select “YES” to switch back to default settings, and press ENTER.

### **Reset - Use this function to reset the unit.**

1. Tap the MENU button until “RSET” is displayed, press ENTER.

2. The fixture will now reset.

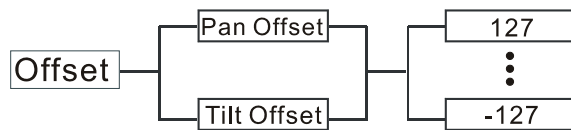

To enter the Pan/Tilt Submenu, press the ENTER button for at least 5 seconds. This submenu allows you to adjust the original position of the Pan and Tilt.

### PAN OFFSET - In this submenu you can adjust the Pan home position.

1. Press the MENU button and then press the ENTER button for at least 5 seconds.
2. Use the UP and DOWN buttons to make your adjustments, and then press ENTER to confirm. Press the MENU button to exit without making changes.

### TILT OFFSET - In this submenu you can adjust the Tilt home position.

1. Press the MENU button and then press the ENTER button for at least 5 seconds.
2. Use the UP and DOWN buttons to make your adjustments, and then press ENTER to confirm. Press the MENU button to exit without making changes.

**Universal DMX Control:** This function allows you to use a Elation® universal DMX-512 controller to control the chases and patterns, dimmer and strobe. A DMX controller allows you to create unique programs tailored to your individual needs. The Inno Color Beam Quad 7 has 2 DMX channel modes; a 1 Channel Mode & 13 Channel Mode. To select your channel mode see page 8.

1. This function will allow you to control each individual fixture's traits with a standard DMX 512 controller such as the Elation® Show Designer™ or the Elation® DMX Operator.™
2. To run your fixture in DMX mode, select your desired channel mode and then set your desired DMX address following the directions on page 8, and the set-up specifications that come with your DMX controller.
3. Plug in the fixture via the XLR connections to any standard DMX controller.
4. For longer cable runs (more than a 100 feet) use a terminator on the last fixture.

**Master-Slave Configuration:** This function will allow you to link up to 16 units together and operate without a controller. The units will be sound activated. In Master-Slave operation one unit will act as the controlling unit and the others will react to the controlling units programs. Any unit can act as a Master or as a Slave.

1. Using approved DMX data cables, daisy chain your units together via the XLR connector on the rear of the units. Remember the Male XLR connector is the input and the Female XLR connector is the output. The first unit in the chain (master) will use the female XLR connector only - The last unit in the chain will use the male XLR connector only. For longer cable runs we suggest a terminator at the last fixture.
2. Set the Master unit to your desired operating mode.
3. On the slave units tap the MENU button until "Slave Mode" is displayed, and Press ENTER. Choose either "Slave 1" or "Slave 2" and press ENTER. See page 9 for more info.
4. The slave units will now follow the Master unit.



Inno Color Beam Quad 7		1 Channel Mode
Channel	Value	Function
1	0 - 7	SHOWS
	8 - 67	BLACKOUT
	68 - 127	SHOW 1
	128 - 187	SHOW 2
	188 - 247	SHOW 3
	248 - 255	SHOW 4
		RANDOM SHOW

Inno Color Beam Quad 7		13 Channel Mode
Channel	Value	Function
1	0 - 255	PAN 0° - 540°
2	0 - 255	PAN FINE
3	0 - 255	TILT 0° - 200°
4	0 - 255	TILT FINE
5	0 - 255	RED 0% - 100%
6	0 - 255	GREEN 0% - 100%
7	0 - 255	BLUE 0% - 100%
8	0 - 255	WHITE 0% - 100%
9	0 - 31	SHUTTER/STROBING
	32 - 63	SHUTTER CLOSED
	64 - 95	OPEN
	96 - 127	STROBING SLOW - FAST
	128 - 159	OPEN
	160 - 191	SLOW OPEN - FAST CLOSE
	192 - 223	OPEN
	224 - 255	RANDOM STROBE SLOW - FAST
		OPEN

Inno Color Beam Quad 7		13 Channel Mode
Channel	Value	Function
10	0 - 255	MASTER DIMMER 0% - 100%
11	0 - 9	RAINBOW
	10 - 39	NO FUNCTION
	40 - 71	RAINBOW COLORS 1
	72 - 103	RAINBOW COLORS 2
	104 - 135	RAINBOW COLORS 3
	136 - 167	RAINBOW COLORS 4
	168 - 199	RAINBOW COLORS 5
	200 - 231	RAINBOW COLORS 6
	232 - 255	RAINBOW COLORS 7
12	0 - 225	CROSSFADING COLORS SLOW - FAST
	226 - 235	PAN/TILT MOVEMENT SPEED
	236 - 255	MAX. - MIN. MOVEMENT SPEED
		BLACKOUT BY MOVEMENT
		NO FUNCTION
13	0 - 79	OPEN/RESET/INTERNAL PROGRAMS
	80 - 84	NORMAL
	85 - 99	ALL MOTOR RESET
	100 - 119	NO FUNCTION
	120 - 139	INTERNAL PROGRAM 1
	140 - 159	INTERNAL PROGRAM 2
	160 - 179	INTERNAL PROGRAM 3
	180 - 199	INTERNAL PROGRAM 4
	200 - 219	INTERNAL PROGRAM 5
	220 - 239	INTERNAL PROGRAM 6
	240 - 255	INTERNAL PROGRAM 7
		SOUND ACTIVE PROGRAM

## Inno Color Beam Quad 7

## Photometric Chart

R	12540	4000	2030	1130	750	(lux)
G	37700	12700	6150	3470	2150	
B	1600	580	290	168	112	
W	36100	11800	5600	3200	2070	
RGBW	87000	29000	14000	7950	5150	

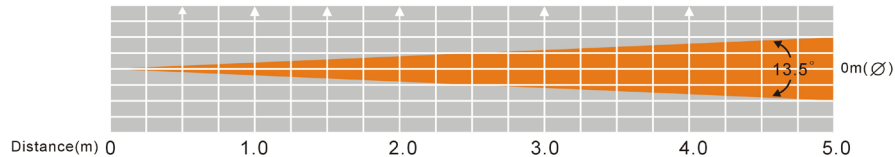

## Inno Color Beam Quad 7

## UC3 Control

Stand By	Blackout the unit			
Function	1. Sync. Strobe 2. Async strobe 3. Sound Strobe	Show 1-4	1. Pan index 2. Tilt index 3. Dimmer	Fade Speed 1. Fast 2. Middle 3. Slow
Mode	Sound (LED OFF)	Show (LED Slow Blinking)	Show (LED Fast Blinking)	LED ON

## Inno Color Beam Quad 7

## Installation

The unit should be mounted using a mounting clamp (not provided), affixing it to the mounting bracket that is provided with the unit. Always ensure that the unit is firmly fixed to avoid vibration and slipping while operating. Always ensure that the structure to which you are attaching the unit is secure and is able to support a weight of 10 times the unit's weight. Also, always use a safety cable that can hold 12 times the weight of the unit when installing the fixture. The equipment must be installed by a professional, and it must be installed in a place where it is out of the reach of people's grasp.

## Inno Color Beam Quad 7

## Power Cord Daisy Chaining

**With this feature you can connect the fixtures to one another using the IEC input and output sockets. The quantity that can be connected is 3 fixtures maximum for 120V, and 5 fixtures maximum for 240V. After the maximum fixtures has been reached you will need to use a new power outlet. They must be the same fixtures. DO NOT mix fixtures.**

## Inno Color Beam Quad 7

## Fuse Replacement

Locate and remove the unit's power cord. Once the cord has been removed located the fuse holder located inside the power socket. Insert a flat-head screw driver into the power socket and gently pry out the fuse holder. Remove the bad fuse and replace with a new one. The fuse holder has a built-in socket for a spare fuse be sure not to confuse the spare fuse with active fuse.

## Inno Color Beam Quad 7

## Cleaning

Due to fog residue, smoke, and dust cleaning the internal and external optical lenses must be carried out periodically to optimize light output.

1. Use a soft cloth to wipe down the outside casing.

Cleaning frequency depends on the environment in which the fixture operates (i.e. smoke, fog residue, dust, dew).

## Inno Color Beam Quad 7

## Troubleshooting

Listed below are a few common problems the user may encounter, with solutions.

### **Unit not responding to DMX:**

1. Check that the DMX cables are connected properly and are wired correctly (pin 3 is "hot"; on some other DMX devices pin 2 may be 'hot'). Also, check that all cables are connected to the right connectors; it does matter which way the inputs and outputs are connected.

### **Unit does not respond to sound:**

1. Quiet or high pitched sounds will not activate the unit.

*If problems are not resolved; Contact ADJ Products, LLC for service.  
1-800-322-6337*

## MANUFACTURER'S LIMITED WARRANTY

- A. ADJ Products, LLC hereby warrants, to the original purchaser, ADJ Products, LLC products to be free of manufacturing defects in material and workmanship for a prescribed period from the date of purchase (see specific warranty period on reverse). This warranty shall be valid only if the product is purchased within the United States of America, including possessions and territories. It is the owner's responsibility to establish the date and place of purchase by acceptable evidence, at the time service is sought.
- B. **For warranty service you must obtain a Return Authorization number (RA#) before sending back the product—please contact ADJ Products, LLC Service Department at 800-322-6337.** Send the product only to the ADJ Products, LLC factory. All shipping charges must be pre-paid. If the requested repairs or service (including parts replacement) are within the terms of this warranty, ADJ Products, LLC will pay return shipping charges only to a designated point within the United States. If the entire instrument is sent, it must be shipped in its original package. No accessories should be shipped with the product. If any accessories are shipped with the product, ADJ Products, LLC shall have no liability whatsoever for loss of or damage to any such accessories, nor for the safe return thereof.
- C. This warranty is void if the serial number has been altered or removed; if the product is modified in any manner which ADJ Products, LLC concludes, after inspection, affects the reliability of the product; if the product has been repaired or serviced by anyone other than the ADJ Products, LLC factory unless prior written authorization was issued to purchaser by ADJ Products, LLC; if the product is damaged because not properly maintained as set forth in the instruction manual.
- D. This is not a service contract, and this warranty does not include maintenance, cleaning or periodic check up. During the period specified above, ADJ Products, LLC will replace defective parts at its expense with new or refurbished parts, and will absorb all expenses for warranty service and repair labor by reason of defects in material or workmanship. The sole responsibility of ADJ Products, LLC under this warranty shall be limited to the repair of the product, or replacement thereof, including parts, at the sole discretion of ADJ Products, LLC. All products covered by this warranty were manufactured after August 15, 2012, and bear indentifying marks to that effect.
- E. ADJ Products, LLC reserves the right to make changes in design and/or improvements upon its products without any obligation to include these changes in any products theretofore manufactured.

No warranty, whether expressed or implied, is given or made with respect to any accessory supplied with products described above. Except to the extent prohibited by applicable law, all implied warranties made by ADJ Products, LLC in connection with this product, including warranties of merchantability or fitness, are limited in duration to the warranty period set forth above. And no warranties, whether expressed or implied, including warranties of merchantability or fitness, shall apply to this product after said period has expired. The consumer's and/or Dealer's sole remedy shall be such repair or replacement as is expressly provided above; and under no circumstances shall ADJ Products, LLC be liable for any loss or damage, direct or consequential, arising out of the use of, or inability to use, this product.

This warranty is the only written warranty applicable to ADJ Products, LLC Products and supersedes all prior warranties and written descriptions of warranty terms and conditions heretofore published. This warranty was revised after December 1, 2012.

## MANUFACTURER'S LIMITED WARRANTY PERIODS:

- **Lighting Products = 1-year (365 days) Limited Warranty** (Such as: Special Effect Lighting, Intelligent Lighting, UV lighting, Strobes, Fog Machines, Bubble Machines, Mirror Balls, Par Cans, Trussing, Lighting Stands etc. excluding LED and lamps)
- **Laser Products = 90-Day Limited Warranty**
- **L.E.D. Products = 3-year (1095 days) Limited Warranty** (excluding motors, PCB boards, and power supplies, which have a 1-year (365 day Limited Warranty) and batteries which have a 180 day limited warranty). Only the L.E.D.s carry a 3-year warranty

**SPECIFICATIONS:**

Voltage:	100V~240V 50Hz/60Hz
LEDs:	7 x 10W Cree Quad RGBW LEDs
Power Consumption:	130W
Beam Angle:	10 Degrees
Fuse:	7Amp
Power Cord Daisy Chain:	3 Fixtures Max. (120V) 5 Fixtures Max. (240V)
Weight:	14lbs./ 6Kgs.
Dimensions:	10.25" (L) x 6.75" (W) x 12" (H) 260 x 168 x 304mm
Colors:	RGBW Color Mixing
DMX Channels:	2 DMX Channel Modes: 1 or 13 Channels
Working Position:	Any safe working position
Warranty:	3 Year (1095 days)

**Auto Sensing Voltage:** *This fixture contains a electronic ballast, which will auto sense the voltage when it is plugged into the power source.*

**Please Note:** Specifications and improvements in the design of this unit and this manual are subject to change without any prior written notice.

ADJ Products, LLC  
 6122 S. Eastern Ave. Los Angeles, CA 90040 USA  
 Tel: 323-582-2650 / Fax: 323-725-6100  
 Web: [www.adj.com](http://www.adj.com) / E-mail: [info@americandj.com](mailto:info@americandj.com)

A.D.J. Supply Europe B.V.  
 Junostraat 2  
 6468 EW Kerkrade  
 Netherlands

Follow Us On:



[facebook.com/americandj](https://facebook.com/americandj)  
[twitter.com/americandj](https://twitter.com/americandj)  
[youtube.com/adjlighting](https://youtube.com/adjlighting)

[service@adjgroup.eu](mailto:service@adjgroup.eu) / [www.adj.eu](http://www.adj.eu)  
 Tel: +31 45 546 85 00 / Fax: +31 45 546 85 99