



ENCORE LPI2IP



User Manual

©2022 ADJ Products, LLC all rights reserved. Information, specifications, diagrams, images, and instructions herein are subject to change without notice. ADJ Products, LLC logo and identifying product names and numbers herein are trademarks of ADJ Products, LLC. Copyright protection claimed includes all forms and matters of copyrightable materials and information now allowed by statutory or judicial law or hereinafter granted. Product names used in this document may be trademarks or registered trademarks of their respective companies and are hereby acknowledged. All non-ADJ Products, LLC brands and product names are trademarks or registered trademarks of their respective companies.

ADJ Products, LLC and all affiliated companies hereby disclaim any and all liabilities for property, equipment, building, and electrical damages, injuries to any persons, and direct or indirect economic loss associated with the use or reliance of any information contained within this document, and/or as a result of the improper, unsafe, insufficient and negligent assembly, installation, rigging, and operation of this product.

DOCUMENT VERSION



Due to additional product features and/or enhancements, an updated version of this document may be available online.

Please check www.adj.com for the latest revision/update of this manual before beginning installation and/or programming.

Date	Document Version	Software Version	DMX Channels	Notes
12/30/2021	1.0	1.02	4 / 7 / 8 / 10 / 13 / 16 channels	Initial Release.
02/18/2022	1.1	1.03	No Change	Updated DMX Traits, added RDM
11/02/2022	1.2	N/C	No Change	Updated Specifications and Dimensional Drawings

Europe Energy Saving Notice

Energy Saving Matters (EuP 2009/125/EC)

Saving electric energy is a key to help protecting the environment. Please turn off all electrical products when they are not in use. To avoid power consumption in idle mode, disconnect all electrical equipment from power when not in use. Thank you!

TABLE OF CONTENTS

Introduction	4
Limited Warranty (USA Only)	5
Warranty Registration Features	6
Safety Guidelines	7
Overview	8
Installation	9
Remote Device Management (RDM)	12
Control Panel	13
System Menu	14
DMX Setup	15
DMX Traits	19
Color Macros Chart	22
Dim Modes	24
Daisy Chain Power Linking Cleaning and Maintenance	25
Dimensional Drawings	26
Specifications	27
Accessory and Ordering Information	28

INTRODUCTION

Unpacking: Thank you for purchasing the Encore LP12IP by ADJ Products, LLC. Every Encore LP12IP has been thoroughly tested and has been shipped in perfect operating condition. Carefully check the shipping carton for damage that may have occurred during shipping. If the carton appears to be damaged, carefully inspect your fixture for any damage and be sure all accessories necessary to operate the unit have arrived intact. In the event that damage has been found or parts are missing, please contact our toll free customer support number for further instructions. Do not return this unit to your dealer without first contacting customer support.

Introduction: The ADJ Encore LP12IP is a DMX intelligent, heavy duty Par. To optimize the performance of this product, please read these operating instructions carefully to familiarize yourself with the basic operations of this unit. These instructions contain important safety information regarding the use and maintenance of this unit. Please keep this manual with the unit for future reference.

Customer Support: Contact ADJ Service for any product related service and support needs. Also visit forums.adj.com with questions, comments or suggestions.

Parts: To purchase parts online visit:

<http://parts.adj.com> (US)

<http://www.adjparts.eu> (EU)

ADJ SERVICE USA - Monday - Friday 8:00am to 4:30pm PST

Voice: 800-322-6337 | Fax: 323-582-2941 | support@adj.com

ADJ SERVICE EUROPE - Monday - Friday 08:30 to 17:00 CET

Voice: +31 45 546 85 60 | Fax: +31 45 546 85 96 | support@adj.eu

ADJ PRODUCTS LLC USA

6122 S. Eastern Ave. Los Angeles, CA. 90040

323-582-2650 | Fax 323-532-2941 | www.adj.com | info@adj.com

ADJ SUPPLY Europe B.V

Junostraat 2 6468 EW Kerkrade, The Netherlands

+31 (0)45 546 85 00 | Fax +31 45 546 85 99

www.americandj.eu | info@americandj.eu

ADJ PRODUCTS GROUP Mexico

AV Santa Ana 30 Parque Industrial Lerma, Lerma, Mexico 52000

+52 (728) 282-7070

CAUTION! There are no user serviceable parts inside this unit. Do not attempt any repairs yourself, as doing so will void your manufacturer's warranty. In the unlikely event your unit may require service, please contact ADJ Products, LLC.

Do not discard the shipping carton in the trash. Please recycle when ever possible.

LIMITED WARRANTY (USA ONLY)

- A. ADJ Products, LLC hereby warrants, to the original purchaser, ADJ Products, LLC products to be free of manufacturing defects in material and workmanship for a prescribed period from the date of purchase (see specific warranty period on reverse). This warranty shall be valid only if the product is purchased within the United States of America, including possessions and territories. It is the owner's responsibility to establish the date and place of purchase by acceptable evidence, at the time service is sought.
- B. For warranty service, you must obtain a Return Authorization number (RA#) before sending the product back—please contact ADJ Products, LLC Service Department at 800-322-6337. Send the product only to the ADJ Products, LLC factory. All shipping charges must be prepaid. If the requested repairs or service (including parts replacement) are within the terms of this warranty, ADJ Products, LLC will pay return shipping charges only to a designated point within the United States. If the entire instrument is sent, it must be shipped in its original package and packaging material. No accessories should be shipped with the product. If any accessories are shipped with the product, ADJ Products, LLC shall incur no liability whatsoever for loss of or damage to any such accessories, nor for the safe return thereof.
- C. This warranty is void if the product serial number and/or labels are altered or removed; if the product is modified in any manner which ADJ Products, LLC concludes, after inspection, affects the reliability of the product; if the product has been repaired or serviced by anyone other than the ADJ Products, LLC factory unless prior written authorization was issued to purchaser by ADJ Products, LLC; if the product is damaged because it was not properly maintained as set forth in the product instructions, guidelines and/or user manual.
- D. This is not a service contract, and this warranty does not include maintenance, cleaning, or periodic check-up. During the period specified above, ADJ Products, LLC will replace defective parts at its expense with new or refurbished parts, and will absorb all expenses for warranty service and repair labor by reason of defects in material or workmanship. The sole responsibility of ADJ Products, LLC under this warranty shall be limited to the repair of the product, or replacement thereof, including parts, at the sole discretion of ADJ Products, LLC. All products covered by this warranty were manufactured after August 15, 2012, and bear identifying marks to that effect.
- E. ADJ Products, LLC reserves the right to make changes in design and/or improvements upon its products without any obligation to include these changes in any products theretofore manufactured.
- F. No warranty, whether expressed or implied, is given or made with respect to any accessory supplied with products described above. Except to the extent prohibited by applicable law, all implied warranties made by ADJ Products, LLC in connection with this product, including warranties of merchantability or fitness, are limited in duration to the warranty period set forth above. And all warranties, whether expressed or implied, including warranties of merchantability or fitness, are limited in duration to the warranty period set forth above. The consumer's and/or dealer's sole remedy shall be such repair or replacement as is expressly provided above; and under no circumstances shall ADJ Product, LLC be liable for any loss and/or damage, direct and/or consequential arising out of the use of, and/or inability to use this product.
- G. This warranty is the only written warranty applicable to ADJ Products, LLC products, and supersedes all prior warranties and written descriptions of warranty terms and conditions heretofore published.

MANUFACTURER'S LIMITED WARRANTY PERIODS:

- Non-LED Lighting Products = 1-Year (365 Days) (Including Special Effect Lighting, Intelligent Lighting, UV lighting, Strobes, Fog Machines, Bubble Machines, Mirror Balls, Par Cans, Trussing, Lighting Stands, Power/Data Distribution, etc. excluding LED and lamps)
- Laser Products = 1-Year (365 Days) (excluding laser diodes which have a 6-Month Limited Warranty)
- LED Products = 2-Year (730 Days) (excluding batteries which have a 180 Day Limited Warranty)
- NOTE: 2-Year (730 Days) Limited Warranty ONLY applies to product purchased within the United States. StarTec Series = 1-Year (365 Days) (excluding batteries which have a 180 Day Limited Warranty)
- ADJ DMX Controllers = 2 Year (730 Days)
- American Audio Products = 1 Year (365 Days)

WARRANTY REGISTRATION

The Encore LP12IP carries a 2 year limited warranty. Please fill out the enclosed warranty card to validate your purchase. All returned service items, whether under warranty or not, must be freight pre-paid and accompanied by a return authorization (R.A.) number. The R.A. number must be clearly written on the outside of the return package. A brief description of the problem as well as the R.A. number must also be written down on a piece of paper included in the shipping carton. If the unit is under warranty, you must provide a copy of your proof of purchase invoice. You may obtain an R.A. number by contacting our customer support team on our customer support number. All packages returned to the service department not displaying an R.A. number on the outside of the package will be returned to the shipper.

FEATURES

The ADJ Encore LP12IP is a versatile, heavy duty Par with twelve (12) 20W Quad LEDs (4-IN-1: Red, Green, Blue & Lime), a 10-degree beam angle, and all metal construction. It is IP65 outdoor rated to protect against, rain, snow and dust for temporary outdoor events. It offers flicker free operation for TV and film and linear white color temperature control from 2700K - 6500K.

INCLUDED ITEMS

- Power Cord (x1)
- Bracket Yoke (x1)
- Frost Filter (x1)

IP RATING

This device is IP65 rated. This means that the unit is dust-tight, and protected against low-pressure jets of water from any direction.

SAFETY GUIDELINES

THIS FIXTURE IS COMPOSED OF SOPHISTICATED ELECTRONIC COMPONENTS. TO GUARANTEE SMOOTH OPERATION, IT IS IMPORTANT TO FOLLOW ALL INSTRUCTIONS AND GUIDELINES IN THIS MANUAL. ADJ PRODUCTS, LLC IS NOT RESPONSIBLE FOR INJURY AND/OR DAMAGES RESULTING FROM THE MISUSE OF THIS FIXTURE DUE TO THE DISREGARD OF THE INFORMATION PRINTED IN THIS MANUAL. ONLY QUALIFIED AND/OR CERTIFIED PERSONNEL SHOULD PERFORM INSTALLATION OF THIS FIXTURE AND ONLY THE ORIGINAL RIGGING PARTS INCLUDED WITH THIS FIXTURE SHOULD BE USED FOR INSTALLATION. ANY MODIFICATIONS TO THE FIXTURE AND/OR THE INCLUDED MOUNTING HARDWARE WILL VOID THE ORIGINAL MANUFACTURER'S WARRANTY AND INCREASE THE RISK OF DAMAGE AND/OR PERSONAL INJURY. ONLY CERTIFIED PERSONNEL SHOULD PERFORM INSTALLATION OF THIS FIXTURE.

- PROTECTION CLASS 1 - FIXTURE MUST BE PROPERLY GROUNDED.
- THERE ARE NO USER SERVICEABLE PARTS INSIDE THIS UNIT.
- DO NOT ATTEMPT ANY REPAIRS YOURSELF; DOING SO WILL VOID YOUR MANUFACTURER'S WARRANTY. DAMAGES RESULTING FROM MODIFICATIONS TO THIS FIXTURE AND/OR THE DISREGARD OF SAFETY INSTRUCTIONS AND GUIDELINES IN THIS MANUAL VOID THE MANUFACTURER'S WARRANTY AND ARE NOT SUBJECT TO ANY WARRANTY CLAIMS AND/OR REPAIRS.
- DO NOT PLUG FIXTURE INTO A DIMMER PACK!
- NEVER OPEN THIS FIXTURE WHILE IN USE!
- UNPLUG POWER BEFORE SERVICING FIXTURE!
- NEVER TOUCH FIXTURE DURING OPERATION, AS IT MAY BE HOT!
- KEEP FLAMMABLE MATERIALS AWAY FROM FIXTURE!
- NEVER LOOK DIRECTLY INTO THE LIGHT SOURCE!
- RETINA INJURY RISK - MAY INDUCE BLINDNESS!
- SENSITIVE PERSONS MAY SUFFER AN EPILEPTIC SHOCK!
- MINIMUM DISTANCE TO OBJECTS/SURFACES IS 6.6 FEET (2 METERS)
- **MAXIMUM AMBIENT TEMPERATURE IS 113° F (45°C). DO NOT OPERATE THE DEVICE WHEN AMBIENT TEMPERATURE EXCEEDS THIS VALUE.**
- **MINIMUM DISTANCE TO FLAMMABLE MATERIALS FROM THE SURFACE IS 1.6 FEET (0.5 METER).**
- DO NOT TOUCH the fixture housing during operation. Turn OFF the power and allow approximately 60 minutes for the fixture to cool down before serving.
- DO NOT shake fixture, and avoid brute force when installing and/or operating fixture.
- DO NOT operate fixture if the power cord is frayed, crimped, damaged and/or if any of the power cord connectors are damaged and do not insert into the fixture securely with ease. NEVER force a power cord connector into the fixture. If the power cord or any of its connectors are damaged, replace it immediately with a new one of the same power rating.
- DO NOT block any air ventilation slots. All fan and air inlets must remain clean and never blocked. Allow approx. 6" (15cm) between fixture and other devices or a wall for proper cooling.
- When installing fixture in a suspended environment, always use mounting hardware that is no less than M10 x 25 mm, and always install fixture with an appropriately rated safety cable.
- Always disconnect fixture from main power source before performing any type of service and/or cleaning procedure.
- Only handle the power cord by the plug end. Never pull out the plug by tugging the wire portion of the cord.
- During the initial operation of this fixture, a light smoke or smell may emit from the interior of the fixture. This is a normal process and is caused by excess paint in the interior of the casing burning off from the heat associated with the lamp and will decrease gradually over time.
- Consistent operational breaks will ensure fixture will function properly for many years.
- ONLY Use original packaging and materials to transport the fixture in for service.

OVERVIEW

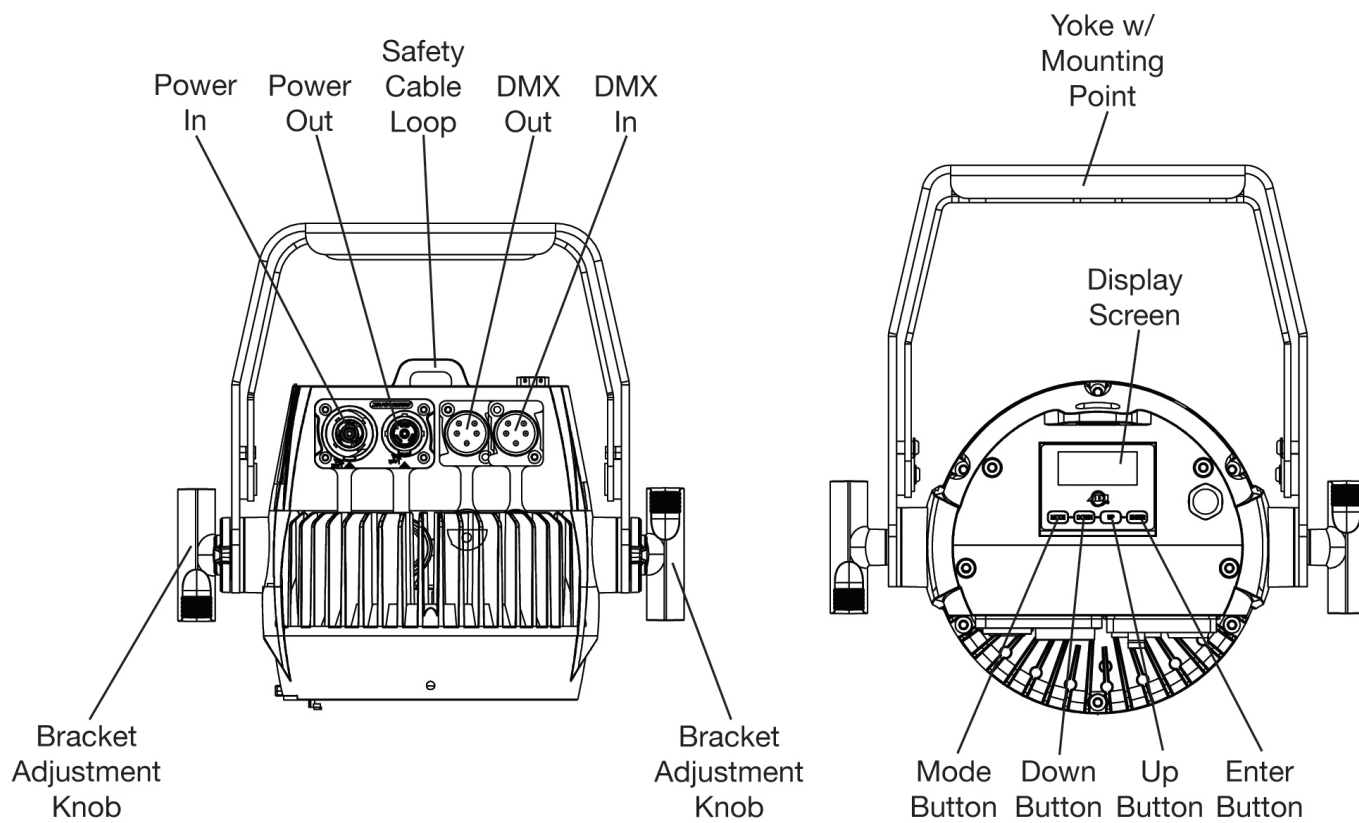

INSTALLATION



FLAMMABLE MATERIAL WARNING

Keep fixture minimum 5.0 feet (1.5m) away from flammable materials and/or pyrotechnics.



ELECTRICAL CONNECTIONS

A qualified electrician should be used for all electrical connections and/or installations.



USE CAUTION WHEN POWER LINKING FIXTURES OF OTHER MODEL TYPES, AS THE POWER CONSUMPTION OF OTHER MODEL FIXTURES MAY EXCEED THE MAX POWER OUTPUT ON THIS FIXTURE. CHECK SILK SCREEN FOR MAX AMPS.



**MINIMUM DISTANCE TO OBJECTS/SURFACES IS 6.6 FEET (2 METERS).
MINIMUM DISTANCE OF INFLAMMABLE MATERIALS FROM THE SURFACE IS 1.6 FEET (0.5 METER)**

DO NOT INSTALL THE FIXTURE IF YOU ARE NOT QUALIFIED TO DO SO!

- Fixture **MUST** be installed following all local, national, and country commercial electrical and construction codes and regulations.
- Before rigging/mounting a single fixture or multiple fixtures to any metal truss/structure or placing the fixture(s) on any surface, a professional equipment installer **MUST** be consulted to determine if the metal truss/structure or surface is properly certified to safely hold the combined weight of the fixture(s), clamps, cables, and accessories.
- Maximum fixture ambient operating temperature is **113°F (45°C)**. Do not use operate the fixture when ambient temperature exceeds this value!
- Fixture(s) should be installed in areas outside walking paths, seating areas, or areas were unauthorized personnel might reach the fixture by hand.
- **NEVER** stand directly below the fixture(s) when rigging, removing or servicing.
- Overhead fixture installation must always be secured with a secondary safety attachment, such as an appropriately rated safety cable.
- Allow approximately 60 minutes for the fixture to cool down before servicing.

IP RATING

This device is IP65 rated. This means that the unit is dust-tight, and protected against low-pressure jets of water from any direction.

RIGGING

Overhead rigging requires extensive experience, including calculating working load limits, installation material being used, and periodic safety inspection of all installation material and the fixture, among other skills. If you lack these qualifications, do not attempt the installation yourself. Improper installation can result in bodily injury.

INSTALLATION

CLAMP INSTALLATION

This fixture features a mounting point on the yoke for the attachment of an Omega bracket and mounting clamp. There is also a safety cable loop located on the rear of the fixture near the display screen (see the illustration below). When mounting the fixture to a truss or any other suspended or overhead installation, be sure to secure appropriately rated clamps and Omega brackets (not included) to the yoke, and attach a separate **SAFETY CABLE** of the appropriate weight rating to the safety cable loop.

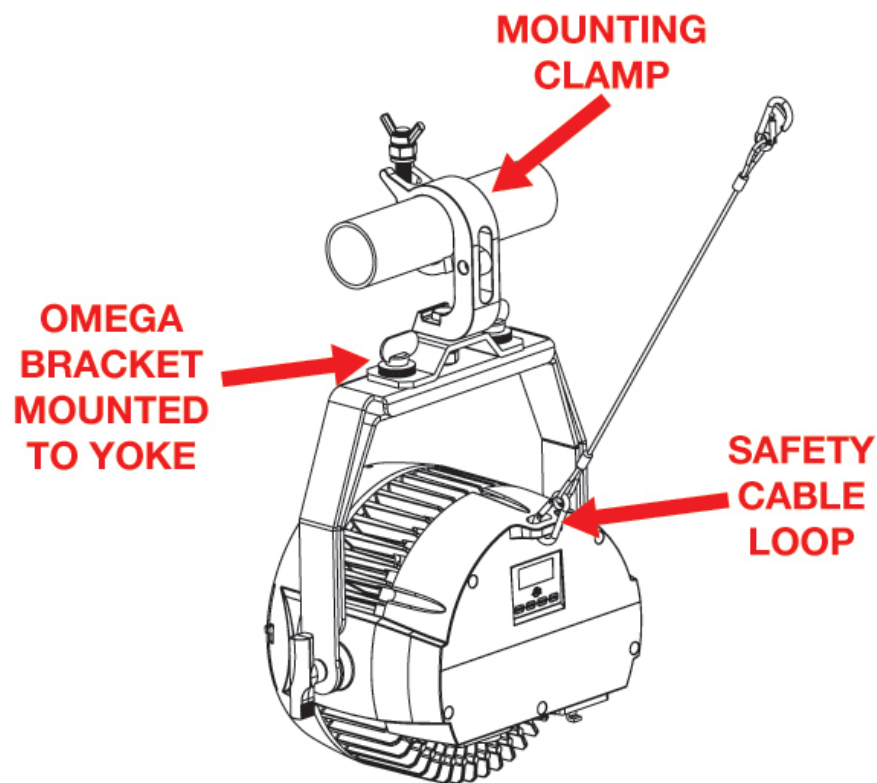

SAFETY CABLE:
ALWAYS ATTACH A SAFETY CABLE WHENEVER INSTALLING THIS FIXTURE IN A SUSPENDED ENVIRONMENT TO ENSURE THAT THE FIXTURE WILL NOT FALL IF THE CLAMP FAILS.

CONNECTIONS

Ensure all connections and end caps are properly sealed with a dielectric grease (available at most electrical suppliers) to prevent corrosion, water intrusion, and/or electrical short circuiting. **In order to maintain IP65 rating integrity and prevent water from entering the fixture, all unused connections must be sealed by closing their protective rubber caps.**

INSTALLATION

POTENTIAL INTERNAL FIXTURE DAMAGE FROM EXTERNAL SOURCES OF LIGHT BEAMS

External sources of light beams from direct sunlight, lighting moving head fixtures, and lasers which are focused directly towards the exterior housing and/or penetrate the front lens opening of ADJ lighting fixtures can cause severe internal damage including burning of optics, dichroic color filters, glass and metal gobos, prisms, animation wheels, frost filters, irises, shutters, motors, belts, wiring, discharge lamps, and LEDs.

This issue is not unique to ADJ lighting fixtures; it is a common issue with lighting fixtures from all manufacturers. Although there is no true way to fully prevent this issue from happening, the guidelines below can reduce the risk of any potential damage if followed. Contact ADJ Service for more details.

DO NOT EXPOSE THE FIXTURE AND/OR FRONT LENS OPENING TO LIGHT BEAMS FROM DIRECT SUNLIGHT, OTHER LIGHTING MOVING HEAD FIXTURES, AND LASERS DURING UNPACKING, INSTALLATION, USE, AND EXTENDED IDLE TIMES OUTDOORS. DO NOT FOCUS A LIGHT BEAM FROM ONE LIGHTING FIXTURE DIRECTLY TOWARDS ANOTHER.

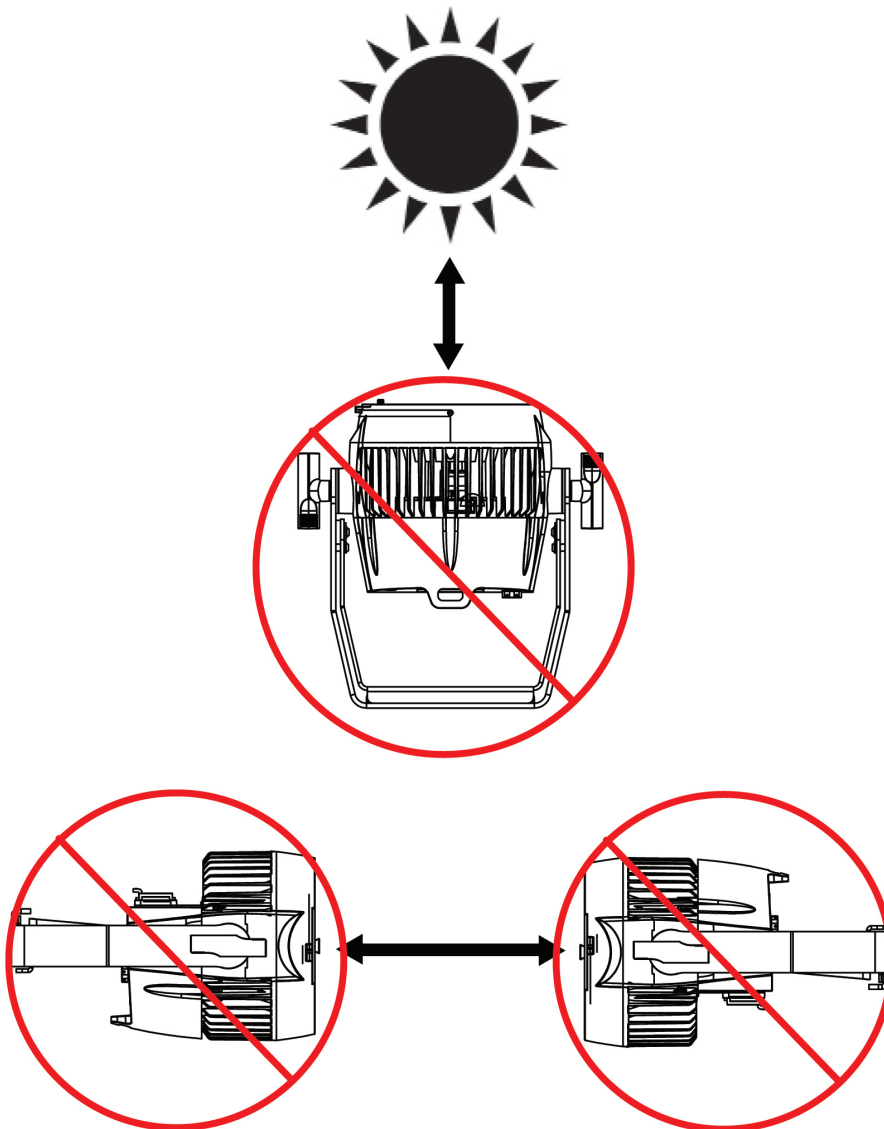

REMOTE DEVICE MANAGEMENT (RDM)

NOTE: In order for RDM to work properly, RDM enabled equipment must be used throughout the entire system, including DMX data splitters and wireless systems.

Remote Device Management (RDM) is a protocol that sits on top of the DMX512 data standard for lighting, allowing the DMX systems of the fixtures to be modified and monitored remotely. This protocol is ideal for instances in which a unit is installed in a location that is not easily accessible.

With RDM, the DMX512 system becomes bi-directional, allowing a compatible RDM enabled controller to send out a signal to devices on the wire, as well as allowing the fixture to respond (known as a GET command). The controller can then use its SET command to modify settings that would typically have to be changed or viewed directly via the unit's display screen, including the DMX Address, DMX Channel Mode, and Temperature Sensors.

Please be aware that **not all RDM devices support all RDM features**, and therefore it is important to check beforehand to ensure that the equipment that you are considering includes all of the features that you require.

The following parameters are accessible in RDM on this device:

MANUFACTURER
MANUFACTURER ID
DEVICE ID
MODEL ID
DMX START ADDRESS
DMX PERSONALITY
DMX SLOTS
SOFTWARE VERSION

CONTROL PANEL

The fixture includes an easy to navigate system menu control panel display where all necessary settings and adjustments are made. (See image below)

- **MODE:** Cycles through the main menu options and/or return to previous menu without making changes.
- **DOWN/UP:** Scroll through options in the selected menu.
- **ENTER:** Select highlighted option and/or confirm selection.

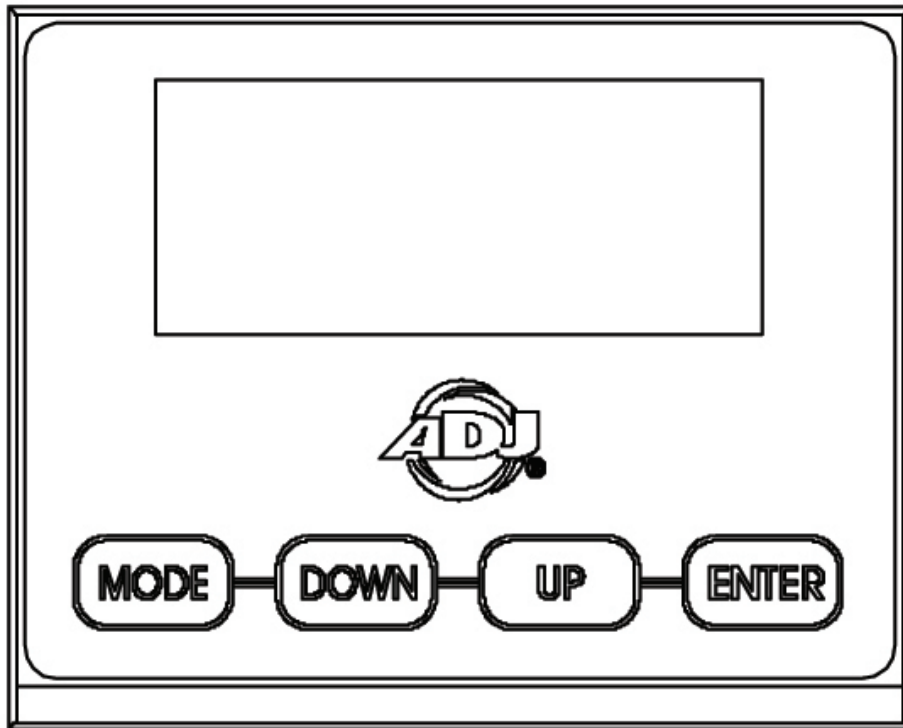

This device features two different settings for locking the keypad. Setting Lock to “ON” requires the user to simply press and hold the MODE button for 10 seconds to unlock the keypad.

Setting Lock to “ON1” provides an additional safeguard against accidental unlocking by requiring a passcode to unlock the device. To unlock, press the MODE button so that “LOCKED *****” is displayed on the screen, then press UP DOWN UP DOWN ENTER in that particular order. Each button press will remove one asterisk from the LOCKED text on the display screen.

SYSTEM MENU

DMX SET	Address	001 - 512		Set DMX address of the unit.
	Ch. Mode	4ch		Set DMX channel mode.
		7ch		
		8ch		
		10ch		
		13ch		
		16ch		
	No DMX	Hold		Unit holds last setting if DMX signal is lost.
		Blackout		Unit goes to standby mode if DMX signal is lost.
Int. Prog		Unit default to last internal program when DMX signal is lost.		
PERSONALITY	Primary	On / Off		Set primary mode.
	Secondary	On / Off		Set secondary mode.
	Fan Set	Auto		
		High		
		Silent		
	Dim Mode	Standard		
		Stage		
		TV		
		Archi.		
		Theatre		
		Stage 2		
		Dim Speed	0.1s - 10s	
	Dim Curve	Square		
		Linear		
		Inv. Squa		
		S. Curve		
	LED Rfrsh	900, 1000, 1100, 1200 , 1300, 1400, 1500, 2500, 4000, 5000, 10k, 15k, 20k, 25k		Set LED refresh rate.
Display	SaveDelay	1 - 10		
	Lock	ON		Press MODE for 10s to unlock
		ON1		Press MODE and display shows LOCKED *****. To unlock, press UP DOWN UP DOWN ENTER.
		OFF		Keypad is unlocked
CONTINUED ON NEXT PAGE				

SYSTEM MENU

PERSONALITY (continued)	Service	Passcode = 050	Calibrat	Red 000 - 255	
				Green 000 - 255	
				Blue 000 - 255	
				Lime 000 - 255	
			S. Update	Yes / No	
Restore: Pass- code = 011	Yes / No	Restore the unit to factory settings.			
MANUAL	Red	000 - 255		Manually adjust red	
	Blue	000 - 255		Manually adjust blue	
	Green	000 - 255		Manually adjust green	
	Lime	000 - 255		Manually adjust lime	
	ClrMacro	00 - 64		Select color macro	
	ClrTemp	000 - 255		Set color temperature	
	ClrTeMac	000 - 255		Set color temp. macro	
	Strobe	000 - 255		Adjust strobe	
	MastrDim	000 - 255		Set master dimmer	
	AutoProg	000 - 255		Select automatic program	
	ProgSpd	000 - 255		Adjust auto program speed	
	ProgFade	000 - 255		Adjust auto program fade	
INTPROGS	Prog 0	Speed	000 - 255		
		Fade	000 - 255		
	Prog 1	Speed	000 - 255		
		Fade	000 - 255		
		
	Prog 7	Speed	000 - 255		
		Fade	000 - 255		
	INFO	Hours	PwrOnHr1	xxx Hrs	Total hours that fixture has been powered on. Non-resettable.
PwrOnHr2			xxx Hrs	Hours that fixture has been powered on since last reset.	
PwrOnRst			Passcode = 050	Reset hours to zero.	

CONTINUED ON NEXT PAGE

SYSTEM MENU

INFO (continued)	Temp.	xxx°	xxx F / xxx C			
		MaxTemp1	xxx F / xxx C		Max temp since last reset.	
		MaxTemp2	xxx F / xxx C		All time max temp, non-resettable.	
		TempRest.	Yes / No	Passcode =	050	Reset LED temp.
	DMX Values	Red				Displays current DMX values for each DMX channel.
		Green				
		...				
		AutoProg				
	SoftVers	x.xx			Displays current software version.	

DMX SETUP

DMX-512: DMX is short for Digital Multiplex. This is a universal protocol used as a form of communication between intelligent fixtures and controllers. A DMX controller sends DMX data instructions from the controller to the fixture. DMX data is sent as serial data that travels from fixture to fixture via the DATA “IN” and DATA “OUT” XLR terminals located on all DMX fixtures (most controllers only have a DATA “OUT” terminal).

DMX Linking: DMX is a language allowing all makes and models of different manufacturers to be linked together and operate from a single controller, as long as all fixtures and the controller are DMX compliant. To ensure proper DMX data transmission, try to use the shortest cable path possible when using several DMX fixtures. The order in which fixtures are connected in a DMX line does not influence the DMX addressing. For example, a fixture assigned a DMX address of 1 may be placed anywhere in a DMX line: at the beginning, at the end, or anywhere in the middle. When a fixture is assigned a DMX address of 1, the DMX controller knows to send DATA assigned to address 1 to that unit, no matter where it is located in the DMX chain.

Data Cable (DMX Cable) Requirements (For DMX Operation): The Encore LP12IP can be controlled via DMX-512 protocol, and features multiple DMX channel modes. Your unit and your DMX controller require a 5-pin XLR connector for data input and data output. If you are making your own cables, be sure to use standard 110-120 Ohm shielded cable (This cable may be purchased at almost all pro lighting stores). Your cables should be made with a male XLR connector at one end and a female XLR connector on the other. Also remember that DMX cable must be daisy chained and cannot be split.

Special Note: Line Termination. When longer runs of cable are used, you may need to use a terminator on the last unit to avoid erratic behavior. A terminator is a 110-120 ohm 1/4 watt resistor which is connected between pins 2 and 3 of a male XLR connector (DATA + and DATA -). This unit is inserted in the female XLR connector of the last unit in your daisy chain to terminate the line. Using a cable terminator (ADJ part number Z-DMX/T) will decrease the chances of erratic behavior.

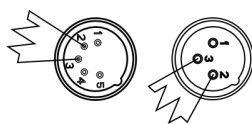

A DMX512 terminator reduces signal errors, avoiding most signal reflection interference. Connect PIN 2 (DMX-) and PIN 3 (DMX+) of the last fixture in series with a 120 Ohm, 1/4 W Resistor to terminate the DMX512.

DMX SETUP

DMX ADDRESSING

All fixtures should be given a DMX starting address when operating with a DMX controller, in order to ensure that the correct fixture responds to the correct control signal. This digital starting address is the channel number from which the fixture starts to “listen” to the digital control signal sent out from the DMX controller. The assignment of this starting DMX address is achieved by setting the correct DMX address on the digital control display on the fixture.

You can set the same starting address for all fixtures or a group of fixtures, or set different addresses for each individual fixture. Setting all fixtures to the same DMX address will cause all fixtures to react in the same way. In this case, please note that changing the settings of one channel will affect all the fixtures simultaneously.

If you set each fixture to a different DMX address, each unit will start to “listen” to the channel number you have set, based on the quantity of DMX channels of each fixture. That means changing the settings of one channel will only affect the selected fixture.

As an example, when operating this device in 4 channel mode, you should set the starting DMX address of the first unit to 1, the second unit to 5 (1 + 4), the third unit to 9 (1 + 4 + 4), and so on. (See the chart below for more details.)

Channel Mode	Unit 1 Address	Unit 2 Address	Unit 3 Address	Unit 4 Address
4 Channels	1	5	9	13
7 Channels	1	8	15	22
8 Channels	1	9	17	25
10 Channels	1	11	21	31
13 Channels	1	14	27	40
16 Channels	1	17	33	49

DMX TRAITS

CHANNEL						DMX VALUE	FUNCTION
4CH	7CH	8CH	10CH	13CH	16CH		
1	1	1	1	1	1	000 - 255	Red , 0% - 100%
		2				000 - 255	Red Fine
2	2	3	2	2	2	000 - 255	Green , 0% - 100%
		4				000 - 255	Green Fine
3	3	5	3	3	3	000 - 255	Blue , 0% - 100%
		6				000 - 255	Blue Fine
4	4	7	4	4	4	000 - 255	Lime , 0% - 100%
		8				000 - 255	Lime Fine
			5	5	5	000 - 255	Color Macros , see Color Macros Chart section for detailed information
			6	6	6	000 - 255	Color Temperature , 2700K - 7000K Linear
							Color Temperature Macros
						000	Off
			7	7	7	001 - 054	2700K
						055 - 109	3200K
						110 - 164	4000K
						165 - 219	5600K
						220 - 255	6500K
							Shutter, Strobe
						000 - 031	LEDs Off
						032 - 063	LEDs On
						064 - 095	Strobe effect, slow to fast
	5		8	8	8	096 - 127	LEDs On
						128 - 159	Pulse-effect in sequences
						160 - 191	LEDs On
						192 - 223	Random strobe effect, slow to fast
						224 - 255	LEDs On
	6		9	9	9	000 - 255	Dimmer Intensity , 0% - 100%
	7		10	10	10	000 - 255	Dimmer Fine
							Auto Programs
						000 - 031	Off
						032 - 063	Auto Program 1
						064 - 095	Auto Program 2
						096 - 127	Auto Program 3
						128 - 159	Auto Program 4

CONTINUED ON NEXT PAGE

DMX TRAITS

CHANNEL						DMX VALUE	FUNCTION
4CH	7CH	8CH	10CH	13CH	16CH		
					11		<i>Auto Programs (continued)</i>
						160 - 191	Auto Program 5
						192 - 223	Auto Program 6
						224 - 255	Auto Program 7
					12	000 - 255	<i>Auto Program Speed</i> , slow to fast
					13	000 - 255	<i>Auto Program Fade</i> , least to most
				11	14		<i>Dim Mode</i>
						000 - 020	Default to unit setting
						021 - 040	Standard
						041 - 060	Stage
						061 - 080	TV
						081 - 100	Architectural
						101 - 120	Theatre
						121 - 140	Stage 2
						141	0.1s dim speed
						142	0.2s dim speed
						143	0.3s dim speed
						144	0.4s dim speed
						145	0.5s dim speed
						146	0.6s dim speed
						147	0.7s dim speed
						148	0.8s dim speed
						149	0.9s dim speed
						150	1.0s dim speed
						151	1.5s dim speed
						152	2.0s dim speed
						153	3.0s dim speed
						154	4.0s dim speed
						155	5.0s dim speed
						156	6.0s dim speed
				157	7.0s dim speed		
				158	8.0s dim speed		
				159	9.0s dim speed		
				160	10.0s dim speed		
				161 - 255	Default to unit setting		

CONTINUED ON NEXT PAGE

DMX TRAITS

CHANNEL						DMX VALUE	FUNCTION
4CH	7CH	8CH	10CH	13CH	16CH		
				12	15		<i>Dim Curves</i>
						000 - 020	Square
						021 - 040	Linear
						041 - 060	Inv. Squa
						061 - 080	S. Curve
						081 - 255	No function
				13	16		<i>Refresh Rate</i>
						000 - 015	Default to Unit Setting
						016 - 030	900 Hz
						031 - 045	1000 Hz
						046 - 060	1100 Hz
						061 - 075	1200 Hz
						076 - 090	1300 Hz
						091 - 105	1400 Hz
						106 - 120	1500 Hz
						121 - 135	2500 Hz
						136 - 150	4000 Hz
						151 - 165	5000 Hz
						166 - 180	10000 Hz
						181 - 195	15000 Hz
						196 - 210	20000 Hz
				211 - 225	25000 Hz		
				226 - 255	No Function		

COLOR MACROS CHART

COLOR MACRO NO.	DMX VALUE	RED	GREEN	BLUE	LIME
Off	000	0	0	0	0
1	001 - 004	80	255	234	80
2	005 - 008	80	255	164	80
3	009 - 012	77	255	112	77
4	013 - 016	117	255	83	83
5	017 - 020	160	255	77	77
6	021 - 024	223	255	83	83
7	025 - 028	255	243	77	77
8	029 - 032	255	200	74	74
9	033 - 036	255	166	77	77
10	037 - 040	255	125	74	74
11	041 - 044	255	97	77	71
12	045 - 048	255	71	77	71
13	049 - 052	255	83	134	83
14	053 - 056	255	93	182	93
15	057 - 060	255	96	236	96
16	061 - 064	238	93	255	93
17	065 - 068	196	87	255	87
18	069 - 072	150	90	255	90
19	073 - 076	100	77	255	77
20	077 - 080	77	100	255	77
21	081 - 084	67	148	255	67
22	085 - 088	77	195	255	77
23	089 - 092	77	234	255	77
24	093 - 096	158	255	144	144
25	097 - 100	255	251	153	153
26	101 - 104	255	175	147	147
27	105 - 108	255	138	186	138
28	109 - 112	255	147	251	147
29	113 - 116	151	138	255	138
30	117 - 120	99	0	255	100
31	121 - 124	138	169	255	138
32	125 - 128	255	255	255	255
33	129 - 132	255	206	143	0
34	133 - 136	254	177	153	0
35	137 - 140	254	192	138	0
36	141 - 144	254	165	98	0

COLOR MACROS CHART

COLOR MACRO NO.	DMX VALUE	RED	GREEN	BLUE	LIME
37	145 - 148	254	121	0	0
38	149 - 152	176	17	0	0
39	153 - 156	96	0	11	0
40	157 - 160	234	139	171	0
41	161 - 164	224	5	97	0
42	165 - 168	175	77	173	0
43	169 - 172	119	130	199	0
44	173 - 176	147	164	212	0
45	177 - 180	88	2	163	0
46	181 - 184	0	38	86	0
47	185 - 188	0	142	208	0
48	189 - 192	52	148	209	0
49	193 - 196	1	134	201	0
50	197 - 200	0	145	212	0
51	201 - 204	0	121	192	0
52	205 - 208	0	129	184	0
53	209 - 212	0	83	115	0
54	213 - 216	0	97	166	0
55	217 - 220	1	100	167	0
56	221 - 224	0	40	86	0
57	225 - 228	209	219	182	0
58	229 - 232	42	165	85	0
59	233 - 236	0	46	35	0
60	237 - 240	8	107	222	0
61	241 - 244	255	0	0	0
62	245 - 248	0	255	0	0
63	249 - 252	0	0	255	0
64	253 - 255	0	0	0	255

DIM MODES

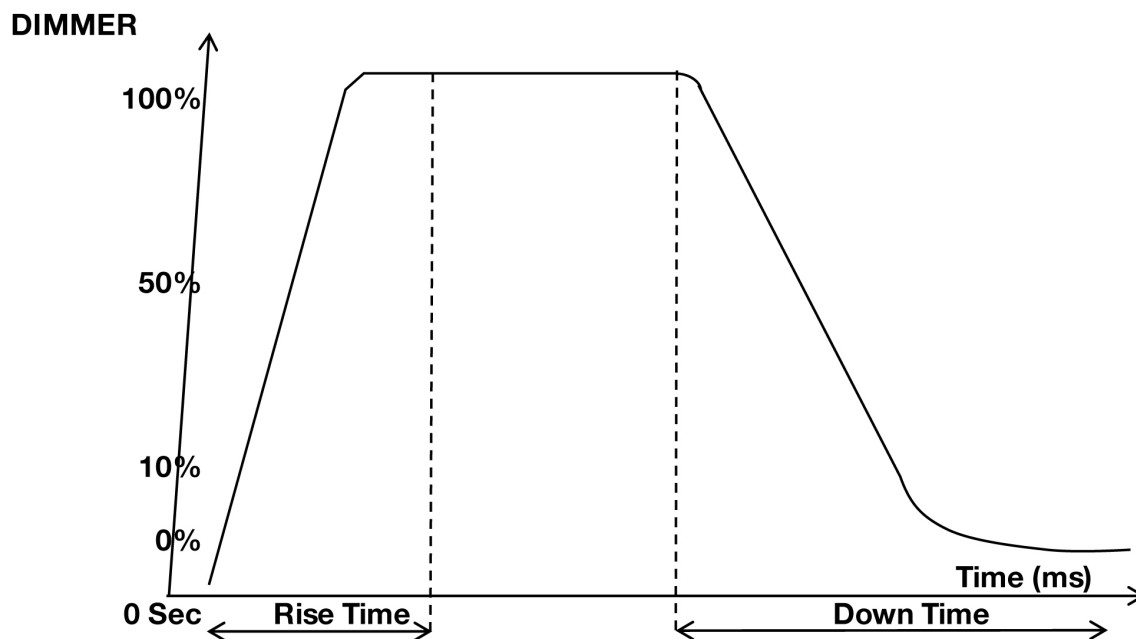

Dimming Curve Ramp Effect	0 sec Fade Time		1 sec Fade Time	
	Rise Time (ms)	Down Time (ms)	Rise Time (ms)	Down Time (ms)
Standard (default)	0	0	0	0
Stage	780	1100	1540	1660
TV	1180	1520	1860	1940
Architectural	1380	1730	2040	2120
Theatre	1580	1940	2230	2280
Stage 2	0	1100	0	1660

DAISY CHAIN POWER LINKING

These units have the capability to be daisy chained together via the power in/out ports. **The maximum number of units that can be linked together in this manner is as follows:**

- **6 units maximum when running on 120V power.**
- **12 units maximum when running on 240V power.**

DO NOT EXCEED THE NUMBER OF UNITS LISTED ABOVE.

DO NOT MIX MAKE AND MODEL TYPES WHEN DAISY CHAINING! All units that are connected in this manner must be of the same make and model type.

CLEANING AND MAINTENANCE

DISCONNECT POWER BEFORE PERFORMING ANY MAINTENANCE!

CLEANING

Frequent cleaning is recommended to ensure proper function, optimized light output, and an extended life. The frequency of cleaning depends on the environment in which the fixture operates: damp, smoky, or particularly dirty environments can cause greater accumulation of dirt on the fixture's optics. Clean the external lens surface periodically with a soft cloth to avoid dirt/debris accumulation.

NEVER use alcohol, solvents, or ammonia-based cleaners.

MAINTENANCE

Regular inspections are recommended to ensure proper function and extended life. There are no user serviceable parts inside this fixture. Please refer all other service issues to an authorized ADJ service technician. Should you need any spare parts, please order genuine parts from your local ADJ dealer.

Please refer to the following points during routine inspections:

- A detailed electrical check by an approved electrical engineer every three months, to make sure the circuit contacts are in good condition and prevent overheating.
- Be sure all screws and fasteners are securely tightened at all times. Loose screws may fall out during normal operation, resulting in damage or injury as larger parts could fall.
- Check for any deformations on the housing, color lenses, rigging hardware, and rigging points (ceiling, suspension, trussing). Deformations in the housing could allow for dust or liquids to enter into the fixture. Damaged rigging points or unsecured rigging could cause the fixture to fall and seriously injure a person(s).
- Electric power supply cables must not show any damage, material fatigue, or sediments.
- **NEVER** remove the ground prong from the power cable.

DIMENSIONAL DRAWINGS

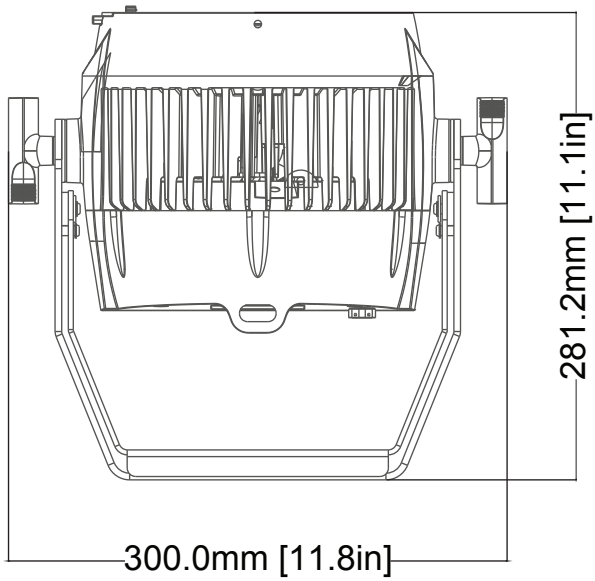
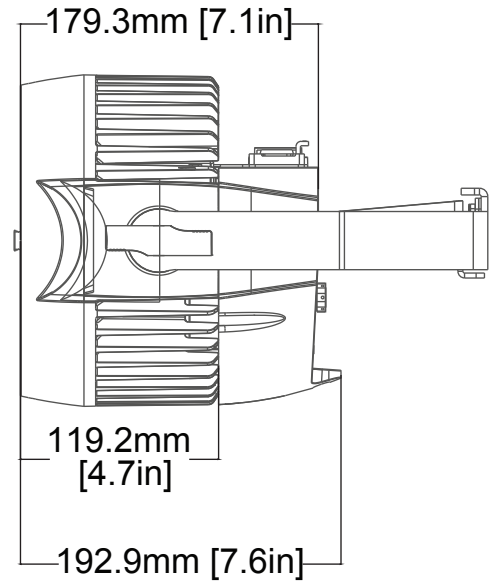
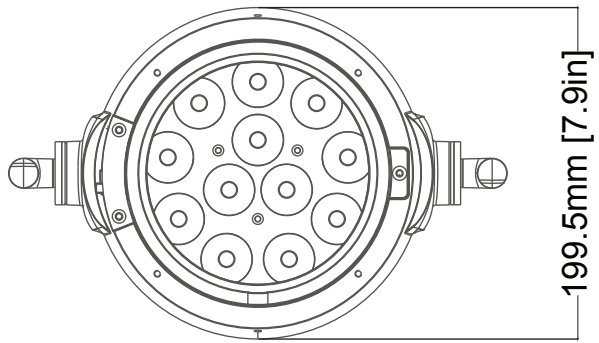

Dimensions may not be drawn to scale.

SPECIFICATIONS

SOURCE:

- Light Source: 12 x 20-Watt Quad RGBL LEDs (4-IN-1: Red, Green, Blue & Lime)

PHOTMETRIC DATA:

- Beam angle: 10-degree
- CRI: 84.4
- CRI R9: 67.9
- Lumens: 4700

EFFECTS:

- Linear Color Temperature Control (2700K to 7000K)
- Preset Color Temperatures (2700K, 3200K, 4000K, 5600K and 6500K)
- 16-Bit Fine Color Control (Red, Green, Blue & Lime)
- 64 built-in Color Macros

CONTROL / CONNECTIONS:

- 4-button, DMX digital display on rear panel
- 5 Operational modes: Static Color Mode, RGBL Dimmer Mode, Program Mode, and DMX Controlled
- Supports RDM (Remote Device Management)
- With Wired Digital Communication Network
- 6 selectable Dimming Modes (Standard, Stage, TV, Architectural, Theatre & Stage 2)
- 4 selectable Dim Curves (Linear, Square Inv. Squa, S-Curve)
- Adjustable Refresh Rate (14 presets from 900 – 25,000Hz)
- Flicker Free operation (No flickering on camera)
- LED pulse and strobe effect
- Electronic Dimming: 0 - 100%
- 6 DMX Modes: 4, 7, 8, 10, 13, & 16-channel
- Quiet fan mode

CONSTRUCTION:

- IP65 Rated: Ingress Protection against liquid, snow, dust and sand
- All metal construction
- IP Rated rubber covers protect In/Out Locking Power connectors and IP rated 5-pin sockets
- Locking, outdoor IN/Out Power connectors
- Data linkable via 5-pin DMX connections
- Includes Lens kit with 4 different beam angles
- Scissor Yoke & safety eye

ELECTRICAL / THERMAL:

- Multi-voltage operation: AC 100-240V, 47/63Hz
- Daisy chain: 6 @ 120V, 12 @ 220V
- Max power: 192W

DIMENSIONS / WEIGHT:

- Dimensions (LxWxH): 7.9" x 11.8" x 11.1" / 199.5mm x 300.0mm x 281.2mm
- Weight: 12.8 lbs. / 5.80 kg.

APPROVALS / RATINGS:

- cETLus Pending
- IP65

Specifications and manual are subject to improvement without prior written notice.

ACCESSORY AND ORDERING INFORMATION

SKU NUMBER	DESCRIPTION
ENC341	ADJ Encore LP12IP
ELP12L100	100-degree Frost Filter
ELP12L60	60-degree Frost Filter
ELP12L20	20-degree Frost Filter
ELP12L30X60	30x60-degree Frost Filter
ELP12L1X40	1x40-degree Frost Filter

